



Thinking solutions.

# Freshwater station



Reflex Hydroflow, Storaflow

# Reflex— a powerful brand for decades

Reflex Winkelmann GmbH is a leading provider of highquality heating and hot water supply technology systems. Under its Reflex brand, the company, which has its headquarters in Ahlen in the German region of Westphalia, develops, produces and sells not only diaphragm expansion vessels, but also innovative components and holistic solutions for pressure maintenance, water make-up, degassing and water treatment, storage water tanks and plate heat exchangers, as well as hydraulic manifold and tank components. Reflex Winkelmann GmbH has about 2,000 employees worldwide, giving it an international presence in all major markets.

With its energy-efficient and sustainable products, the company is already doing its bit to help the environment, as evidenced by its commitment to sustainability and the climate policy goals agreed by the German Federal Government. This support is built on proven technologies and future-oriented innovations. What's more, Reflex Winkelmann GmbH works together with others as equals, always maintains its focus on the customer and offers additional services such as its own factory service centre fleet and a comprehensive range of training options.

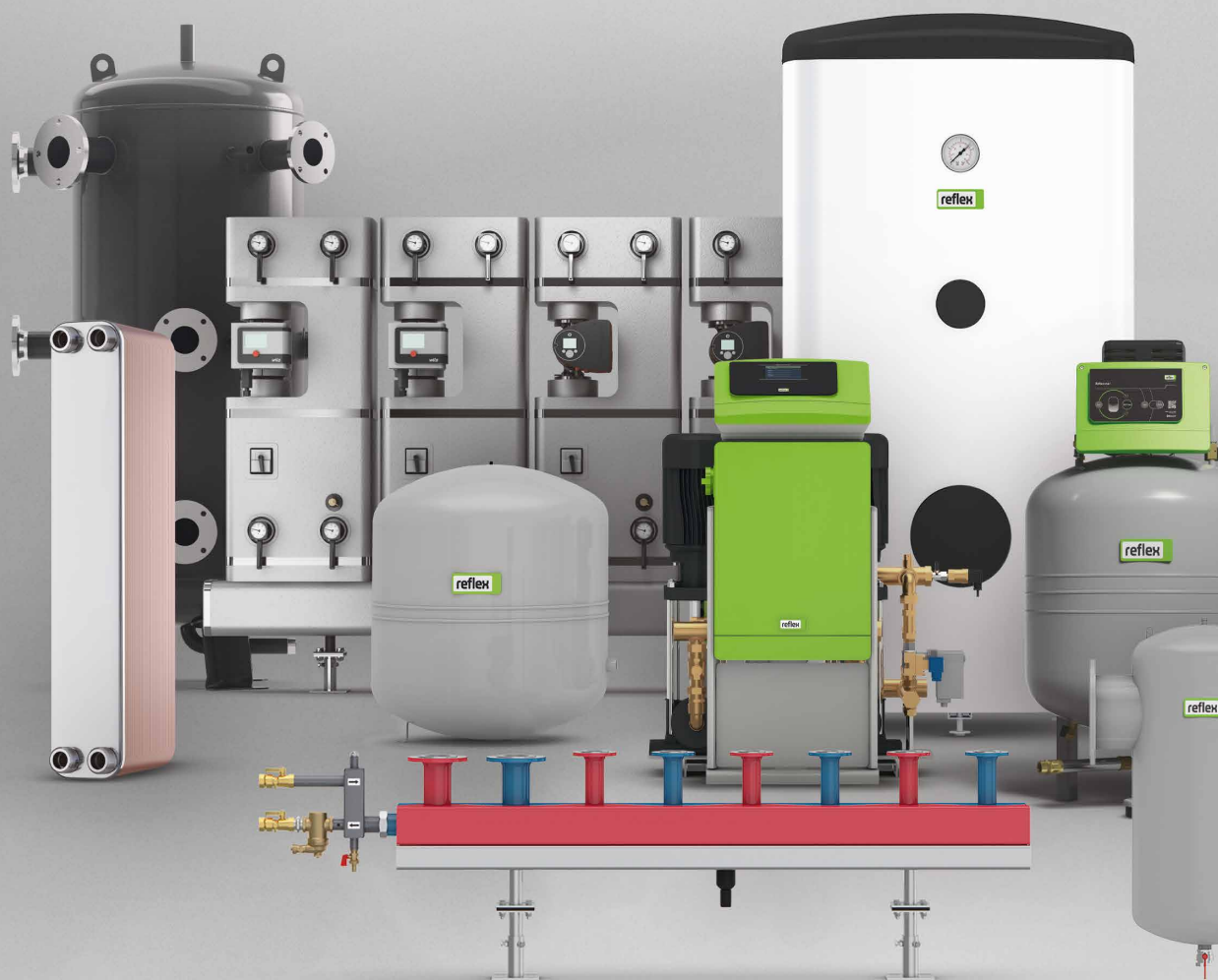



# Contents

<b>Reflex City</b>	p. 4
<b>Freshwater systems</b>	p. 6
Product overview	p. 8
<b>Reflex Hydroflow</b>	
Key benefits	p. 9
Construction, function, application	p. 10
Product range Reflex Hydroflow	p. 13
<b>Storaflow</b>	
Key benefits	p. 19
Construction, function, application	p. 20
Product range Storaflow	p. 21
<b>Selection and calculation</b>	p. 24
<b>Installation and commissioning</b>	p. 30
<b>Flexible overall system from Reflex</b>	p. 36
<b>Cascading</b>	p. 38
<b>Reflex added value</b>	p. 42

## Our configuration software



Reflex Solutions Pro

[rsp.reflex.de/en](https://rsp.reflex.de/en)

→ Find out more on [page 42](#)





## Storaflow

### Freshwater stations—for optimum potable water

Living, shopping, working and producing—city-life means diversity. And the demands on supply technology are as individual as the buildings themselves. Whether it's a 5 kW system in a detached home or a safety-related cooling system in a computer centre—Reflex offers products and solutions of all sizes and complexities. This self-image is reflected in the Reflex City concept.

Hot water on demand, optimum hygiene and maximum convenience. Reflex Hydroflow provides hot potable water for small to medium-sized systems. The freshwater station is particularly suitable for applications with extremely high hygiene requirements, such as in hospitals or schools, but end users in detached private properties and multi-occupancy buildings also benefit from a convenient and rapid potable water supply.

# Freshwater systems

## Potable water hygiene

Hot potable water must be available quickly for everyday use, whether for showering, washing hands or preparing food. A potable water storage tank can be used to provide potable water but this is an energy-intensive solution.

Any standing water can lead to proliferation of bacteria, even if advanced heating technology is in use. This is the perfect application for freshwater stations as they offer ideal setup and conditions for the rapid and hygienic provision of potable water — without having to store it beforehand.

## General information on freshwater stations

A freshwater station consists of a heat exchanger, a pump, temperature sensors, a regulator and the relevant hot water storage tank. The station provides hot potable water on demand by heating potable water to the required temperature in the heat exchanger using heating water flowing from the hot water storage tank in the opposite direction.

The physical separation of potable water and heating water ensures high hygiene standards are maintained against bacteria such as legionella. Depending on the size, freshwater stations can be used in residential properties as well as in larger public buildings where there are high hygiene demands, such as in hospitals or schools.

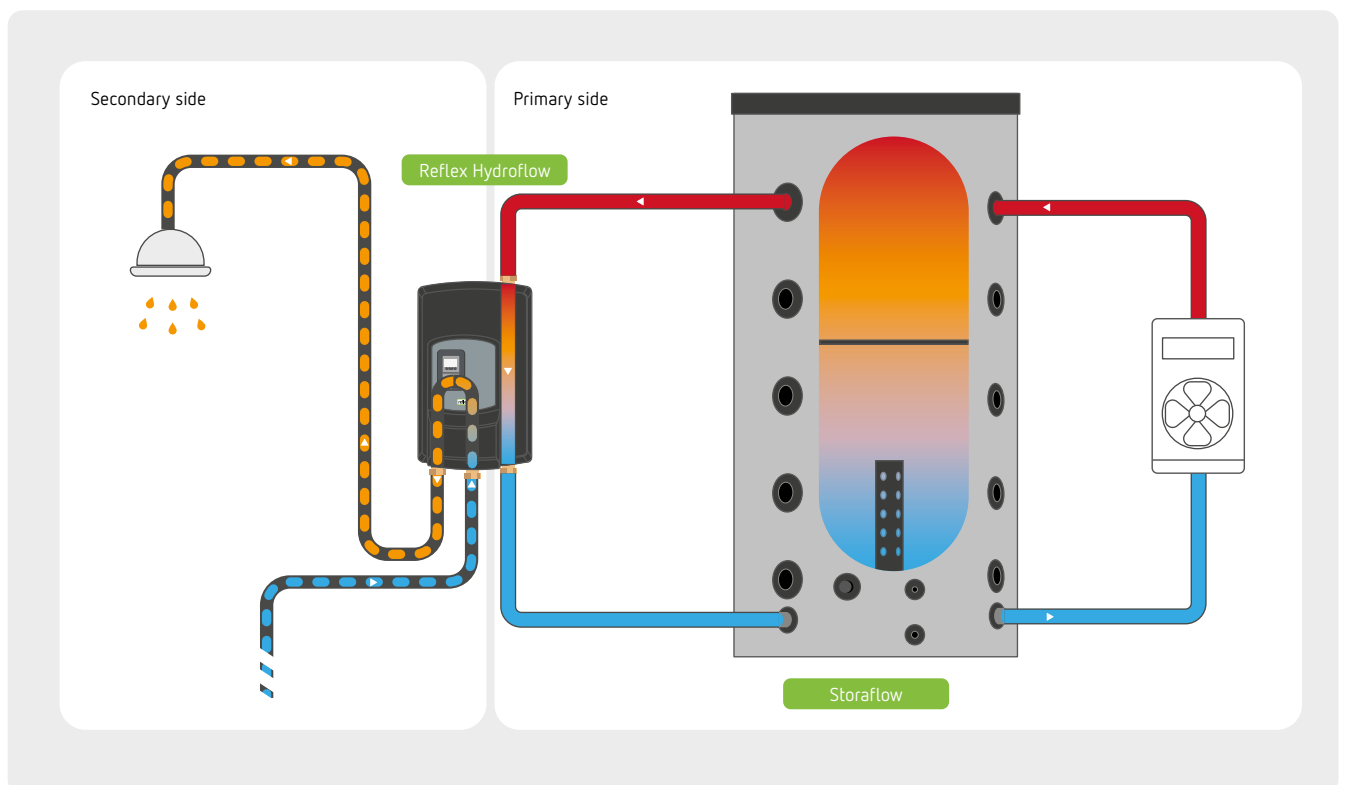

## Reflex freshwater systems

If needed, the freshwater station is available directly from Reflex as a complete system. In these instances, the freshwater station has an additional buffer tank and a manifold so there is no need for expensive installation work. The components are matched to each other so there is no need for extended research for appropriate system components, providing significant savings in time and money for both installers and planners.

The freshwater station, hot water storage tank and manifold are all available in a range of sizes, allowing specific requirements to be precisely met. Individual components or combinations are also available in addition to complete systems.

1. **Reflex Hydroflow** freshwater station
2. Manifold by **SINUS**
3. **Storaflow** buffer tank



## Combination matrix

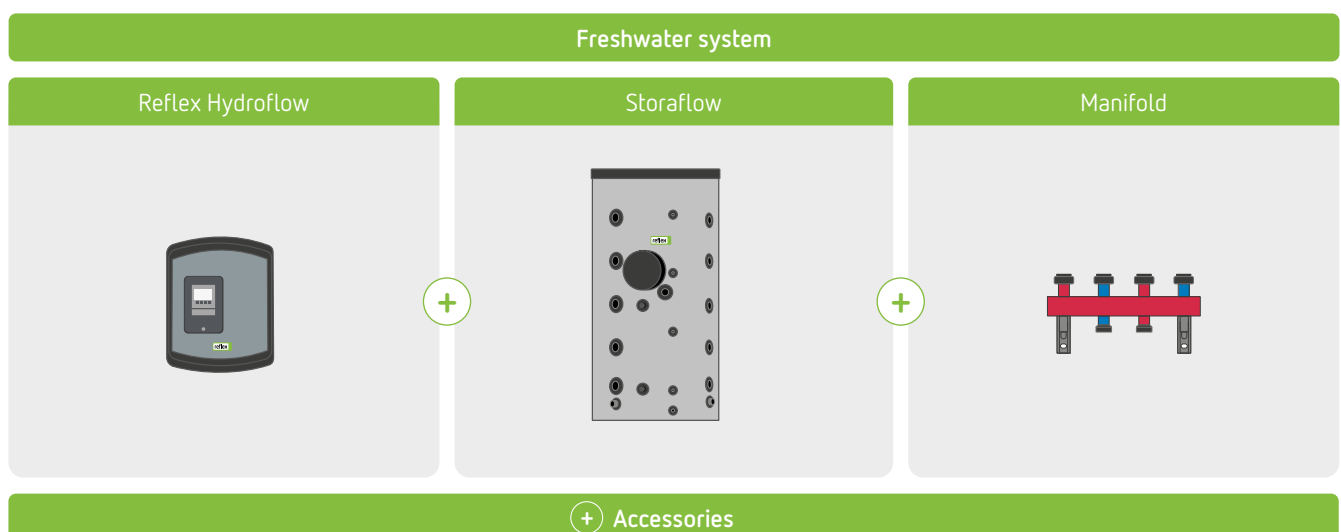

# Product overview

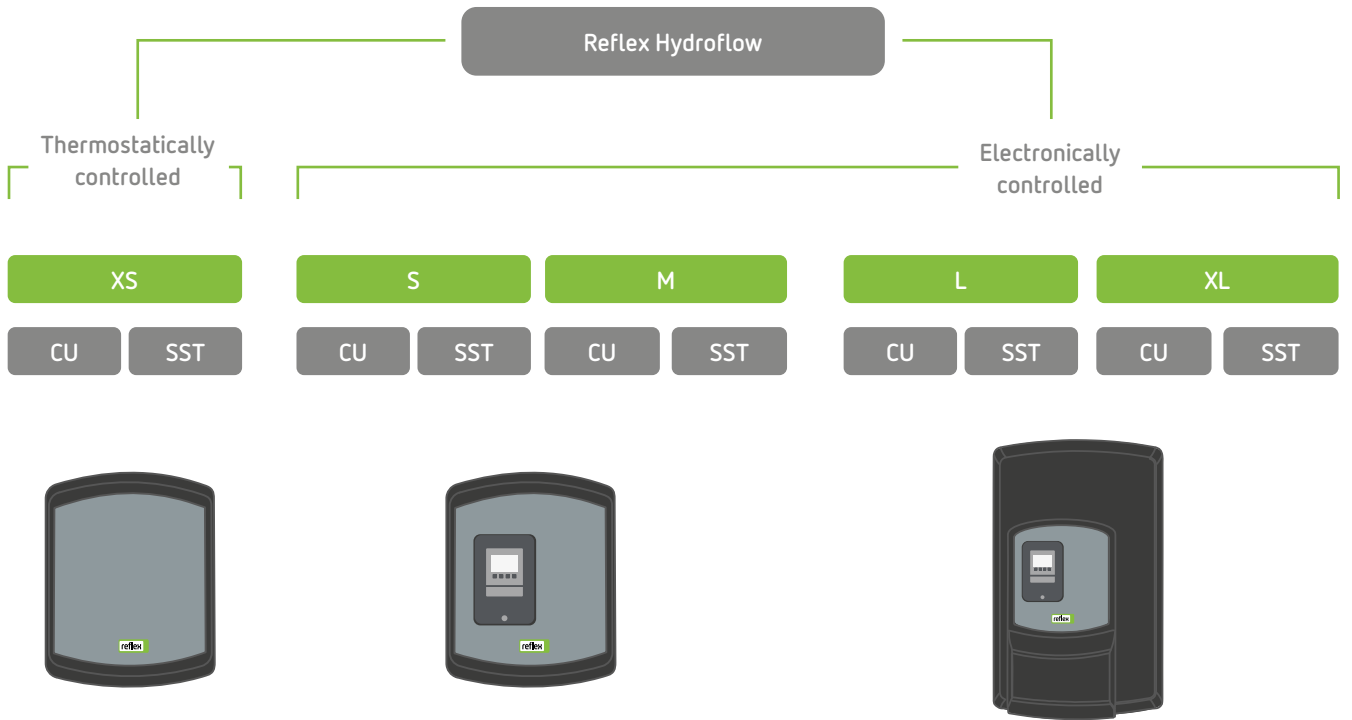

CU = single-wall heat exchanger—copper-brazed  
SST = single-wall heat exchanger—stainless steel-brazed

# Reflex Hydroflow

## Key benefits

### Hygienic construction and function

- Continuous flow principle ensures optimum hygiene at all times
- Minimises development of legionellae
- Adjustable thermal disinfection, e.g. for hospitals
- 100 % stainless steel heat exchanger version available as option

### Convenient installation and service

- Telephone service support
- Easy installation thanks to comprehensive Plug & Play accessory

### Flexible use

- Can be combined with hot water storage tanks up to 2000 l
- Flexible adaptation possible by cascading fresh-water stations
- Range of operating modes

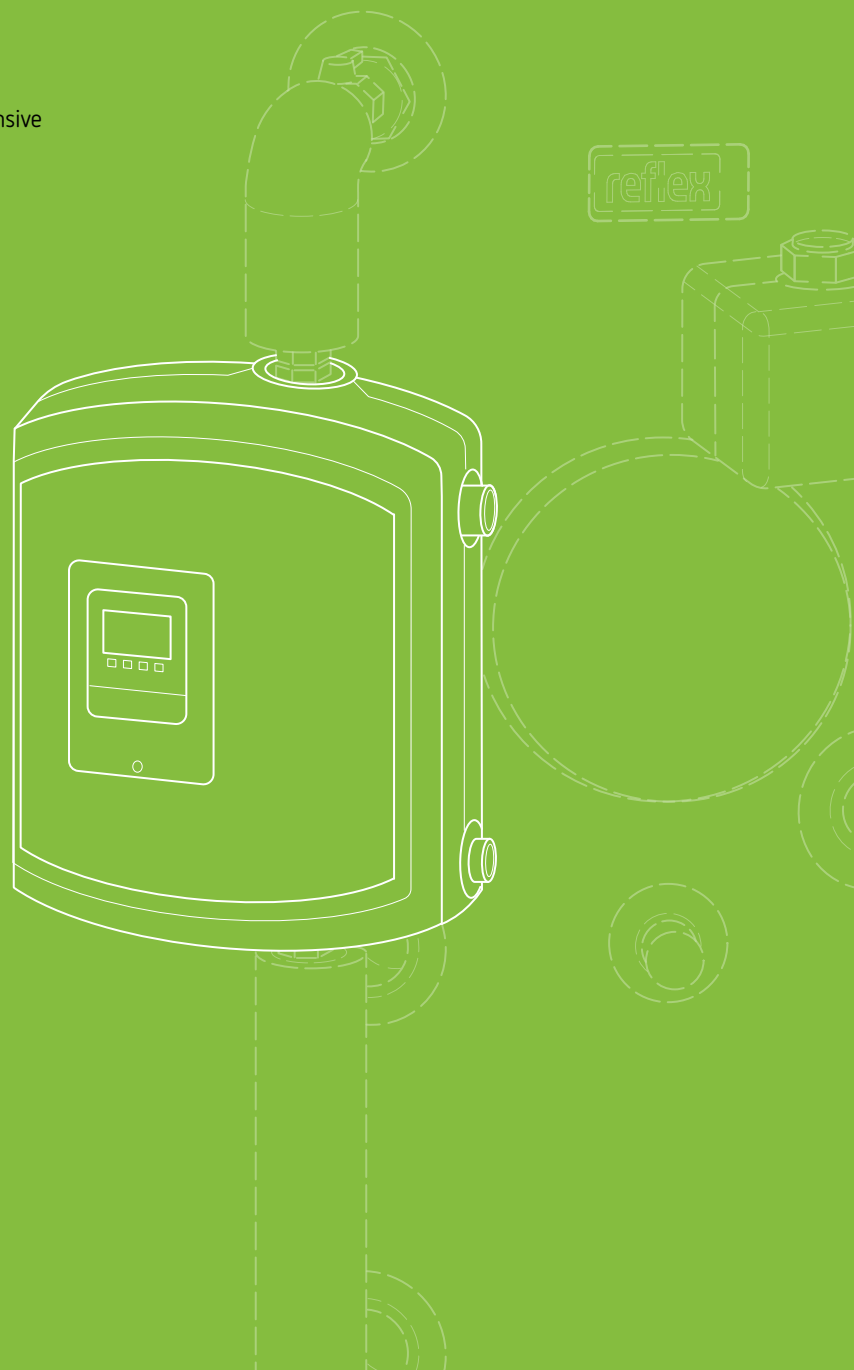

# Construction, function, application

## Reflex Hydroflow construction



Reflex Hydroflow S–M freshwater station models

1. **Heating system flow**  
The heated water is pumped out of the hot water storage tank into the freshwater station here.
2. **Heating system return**  
The heating water that has cooled down in the heat exchanger is stratified back into the Storaflow buffer cylinder via the pipework.
3. **Cold water feed**  
Potable water from the municipal supply is transported into the freshwater station by tapping.
4. **Hot water outlet**  
The hot water outlet pipework is connected here. The heated potable water is fed into the system from here.
5. **Heat exchanger**  
The high temperature of the heating water is transferred to the potable water using the counterflow principle.
6. **Pump**  
The pump circulates the heated water between the buffer tank and the heat exchanger. It is controlled by the regulator.



Reflex Hydroflow L–XL freshwater station models

7. **Temperature sensor**  
The two temperature sensors measure the water temperature in the pipes—once at the heating system flow and once at the heating system outlet. This registers the transfer of the heating water temperature to the potable water.
8. **Volume flow sensor**  
The flow rate of the water is determined via the volume flow sensor and transferred to the regulator as information.
9. **Regulator**  
The regulator is the central control unit of the freshwater station. All the data from the temperature sensors are collated here. They indicate whether the water is being moved to the hot water outlet at the required temperature. The information from the volume flow sensor is also processed here and used to control the pump.
10. **Vent**  
The vent is used during maintenance work and commissioning. It eliminates air inclusions from the system.
11. **Circulation set\***  
This pre-assembled unit serves to maintain the temperature at every point in the hot water system.

## How it works

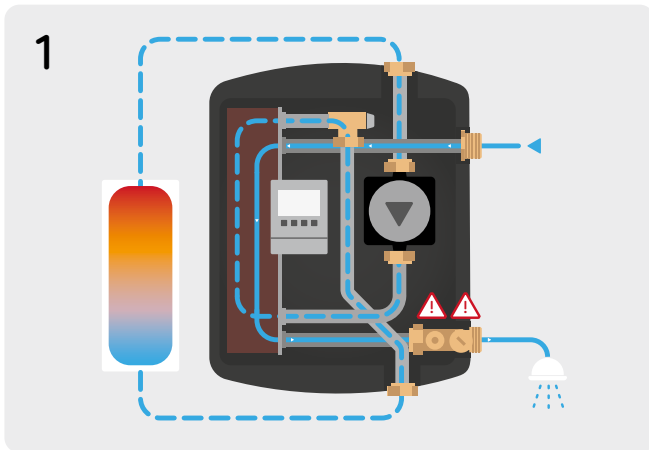

### 1. Tapping starts

The Reflex Hydroflow freshwater station only makes hot water available when hot water is tapped and avoids storing quantities of water. This tapping signal occurs when a user requests heated potable water. The integral volume flow sensor registers the flow of water while the connected temperature sensor indicates if the temperature is still too low.

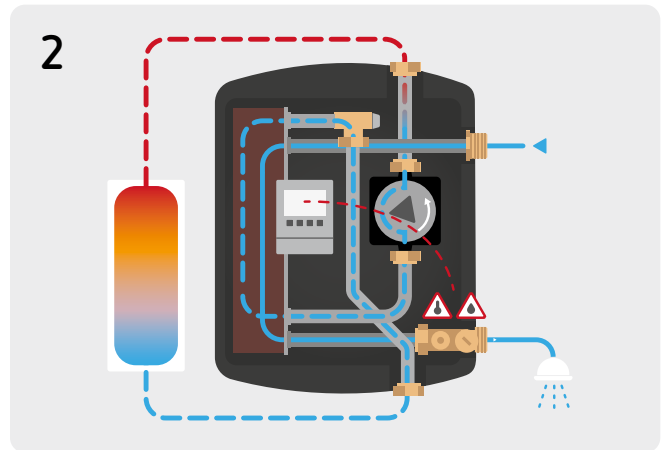

### 2. Pump is activated

This information is provided as a bundle to the regulator on the freshwater station which then activates the pump to direct hot water from the Storaflow buffer tank to the station. It flows through the Reflex Hydroflow freshwater station's heat exchanger in the opposite direction and transfers the heat to the potable water. The large surface area of the heat exchanger plates ensures maximum heat exchange to the potable water.

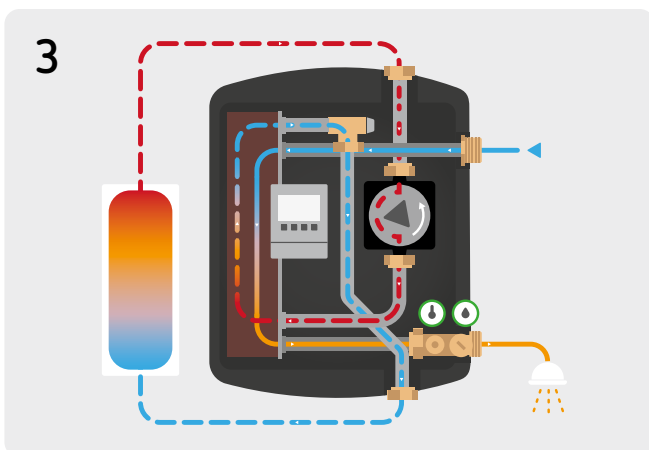

### 3. Potable water heating and regulation

The potable water at the appropriate temperature is supplied via the heat exchanger and passes through both the volume flow sensor and the temperature sensor. Both send the relevant data to the regulator which adjusts the volume flow steplessly by altering the pump speed.

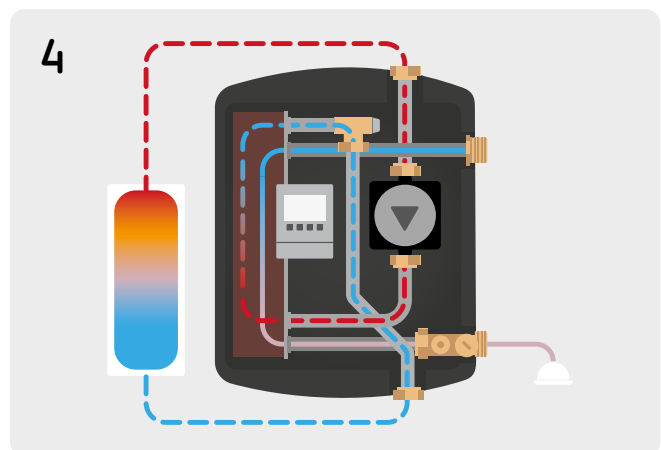

### 4. Tapping ends

The cooled heating water is returned to the Storaflow buffer tank and stratified in the cold layer of the buffer tank. This water is heated again in the next iteration and is once again made available to the Reflex Hydroflow freshwater station for subsequent requirements.

## Three control regulator modes

### Automatic

The regulator's standard operational mode is automatic. Correct functionality of the regulator taking into consideration the current temperatures and the target parameters is only available in automatic mode.

### Manual

The relays, and therefore the connected actuators such as pumps and valves, are switched on or off by pressing buttons without taking the current temperatures and the target parameters into consideration. The current measured values from the temperature sensors are simultaneously displayed to control the function. This function is only to be used by installers or specialist tradespeople for short-term functional testing, for example, when commissioning.

### Emergency

The primary pump is run at 50 % of the maximum speed, irrespective of the values from the freshwater station sensors to ensure hot water is supplied for the duration of the emergency. Heat energy present in the buffer tank is not taken into consideration. Emergency mode must be switched off manually. Suitable protection against scalding is to be provided depending on the heat source and maximum buffer temperature.

## Reflex Hydroflow potential applications

The Reflex Hydroflow freshwater station can be flexibly integrated into a wide range of system sizes thanks to the many different versions and possible combinations. The freshwater station is most beneficial where hygiene is a particular priority.

### Reflex Hydroflow XS

- Thermostatic regulation
- Compatible with 500 to 2000 l Storaflo buffer tank portfolio
- For installation on the hot water storage tank or wall



### Reflex Hydroflow S – M

- Integral electronic regulation
- Compatible with 500 to 2000 l Storaflo buffer tank portfolio
- For installation on the hot water storage tank or wall



### Reflex Hydroflow L – XL

- Integral electronic regulation
- Potable water safety valve
- Stopcocks on the buffer tank side
- Compatible with 800 to 2000 l Storaflo buffer tank portfolio
- For installation on the hot water storage tank or wall



# Product range Reflex Hydroflow

## Reflex Hydroflow



Reflex Hydroflow XS



Reflex Hydroflow S / M



Reflex Hydroflow L



Reflex Hydroflow XL

### Technical Features

- electronically controlled mains water station with mains water regulator, can be cascaded several times for large tap capacities
- compact modular design
- hygiene programme and thermal disinfection for maximum protection
- completely pre-assembled for connection to the storage tank circuit and potable water system
- with built-in controller, prewired
- power supply 230V/50 Hz
- comfort function for keeping the pipework on the primary side warm
- floating target value, reduction of the hot water target temperature if the buffer temperature is insufficient
- circulation pump set for integration into the Reflex Hydroflow L or modularly expandable with Reflex Hydroflow S, M and XL
- control of time, temperature and demand possible
- permissible operating overpressure 10 bar
- permissible operating temperature 95 °C

Type	Art. No.	Nominal width	Connection heating side	Connection potable water side	Nominal capacity 10-45 °C/65 °C [kW]	Tap capacity 10-45 °C/65 °C [l/min]	NL number	Weight [kg]
XS – CU	9583531	DN 20	G1"	G1"	60.0	25	3.47	8.31
XS – SST	9583532	DN 20	G1"	G1"	60.0	25	3.47	8.31
S – CU	9583533	DN 20	G1"	G1"	70.0	29	4.76	7.89
S – SST	9583534	DN 20	G1"	G1"	70.0	29	4.76	7.89
M – CU	9583535	DN 20	G1"	G1"	100.0	41	9.59	9.18
M – SST	9583536	DN 20	G1"	G1"	100.0	41	9.59	9.18
L – CU	9583538	DN 25	G1"	Rp ¾"	126.9	52	15.04	23.23
L – SST	9583539	DN 25	G1"	Rp ¾"	126.9	52	15.04	23.23
XL – CU	9583541	DN 32	G 1 ½"	G 1 ¼"	190.0	80	32.11	27.11
XL – SST	9583542	DN 32	G 1 ½"	G 1 ¼"	190.0	80	32.11	27.11

## Reflex Hydroflow accessories\*



### Commissioning

- **7945725**: Reflex commissioning Cat. 3 for Reflexomat Silent Compact/Reflexomat XS/Servitec S with one compressor/one pump or Reflex Hydroflow freshwater station
- **7945726**: Reflex commissioning add. Cat. 3 for each additional system at the same location – one compressor/pump



### Free-flow valve

- minimises pressure surges on the potable water installation
- installation on the potable water inlet side



### BMS module

- extension module for the controller to indicate a group fault to an external building management system



### Heating water mixer

- regulates the temperature of the heating water at high temperatures, e.g. 90 °C in the flow to the mains water station, downwards to a lower level by adding cooler service water to the buffer flow — cold water is on the secondary side (potable water) to additionally increase hot water comfort
- **note**: the heating water mixer reduces the tap capacity or tap volume by up to approx. 25 %!
- suitable for Reflex Hydroflow XS, S, M



### Cascade ball valve

- switching off or connecting individual stations connected in parallel as required
- including actuator



### Cascade piping

- space-saving installation
- consisting of pipes for the heating-water and potable-water side
- pipes already insulated



### Ball valve set

- enables ball valves to be fitted to shut off the system during maintenance work or replacement
- heating side VL/RL Rp 3/4" – AG 1"
- hot water Rp 3/4" – ÜWM G 1"



### Ball valve set M — cascade pipework

- enables the ball valves to be fitted and connects the cascade pipework of the mains water station
- switching off or connecting individual stations connected in parallel as required
- including actuator



\* Accessories must be ordered separately

## Reflex Hydroflow accessories\*



### Installation set

- installation set for L & XL stations as single station on Storaflow hot water storage tank including screws and nuts
- enables direct installation on the Storaflow hot water storage tank via the 2" sleeves



### Return stratification M

- controls the energy-efficient stratification of the return water in the hot water storage tank
- for hot water storage tanks without stratified charging pipe
- 3-way DN 32 valve with two sensors



### Return stratification L

- controls the energy-efficient stratification of the return water in the hot water storage tank
- for hot water storage tanks without stratified charging pipe



### Connection cable set

- connection cable set for mains water cascade with matching plugs and terminating resistors



### Circulation unit S / M

- ensures a continuous supply of hot water to the end consumer circuits
- contains circulation pump, gravity brake and temperature sensor
- circulation unit S/M with 2 shut-off ball valves



### Circulation unit L / XL

- ensures a continuous supply of hot water to the end consumer circuits
- contains circulation pump, gravity brake and temperature sensor
- circulation unit L/XL with one shut-off ball valve and thermometer



Type	Art. No.	Weight [kg]
Commissioning Cat. 3	7945725	–
Free-flow valve XL	9583561	0.75
Commissioning add. Cat. 3	7945726	–
BMS module	9583608	0.10
Heating water mixer	9583563	1.17
Cascade ball valve L	9583557	1.01
Cascade ball valve XL	9583562	2.08
Cascade piping M	9583554	5.14
Cascade piping L	9583558	13.43
Ball valve set XS/S/M	9583551	1.06
Ball valve set cascade M	9583552	2.63
Installation set L/XL	7938480	4.20
Return stratification M	9583555	1.68
Return stratification L/XL	9583559	2.61
Connection cable set	9583609	0.03
Circulation unit S/M	9583553	3.02
Circulation unit L/XL	9583556	2.74

\* Accessories must be ordered separately

## Reflex Hydroflow performance diagrams

### Reflex Hydroflow XS

Hot water temperature 45°C 50°C 55°C 60°C 65°C

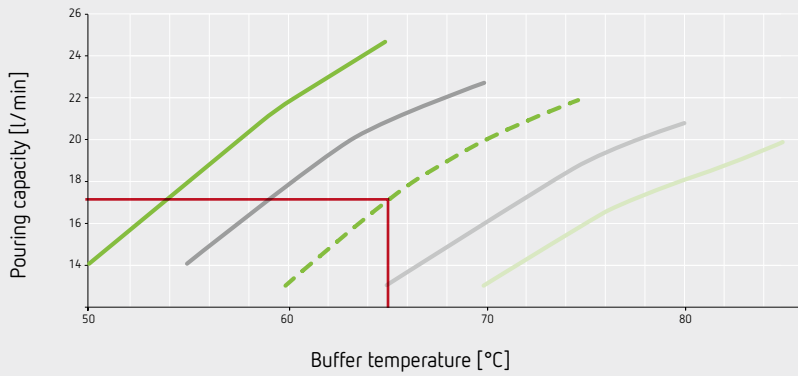

**Reading example**

Buffer temperature = 65 °C

Hot water temperature = 55 °C

→ Max. pouring capacity = 17 L/min

### Reflex Hydroflow S

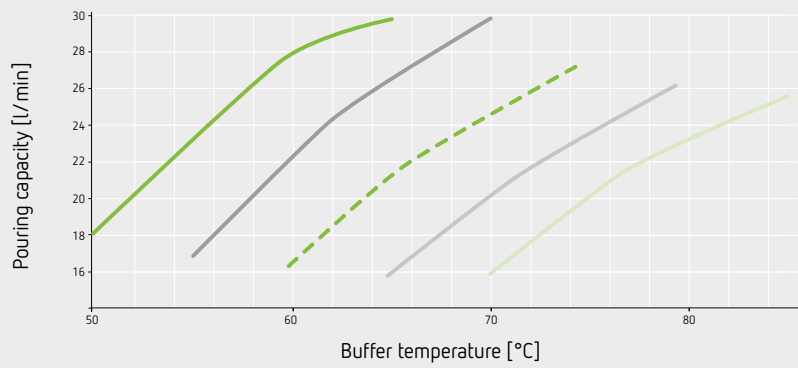

## Reflex Hydroflow performance diagrams

### Reflex Hydroflow M

Hot water temperature 45°C 50°C 55°C 60°C 65°C

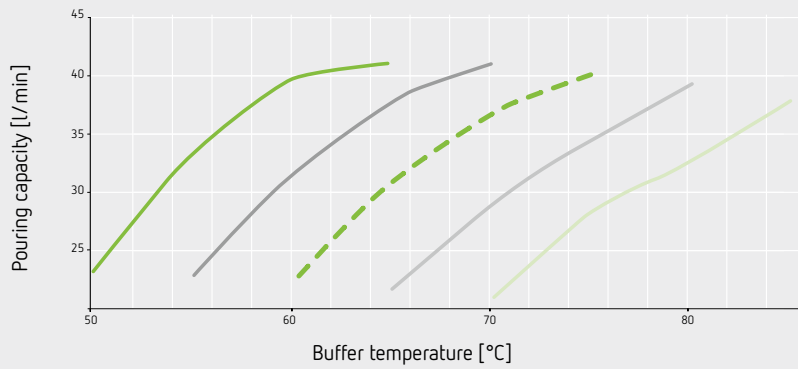

### Reflex Hydroflow L

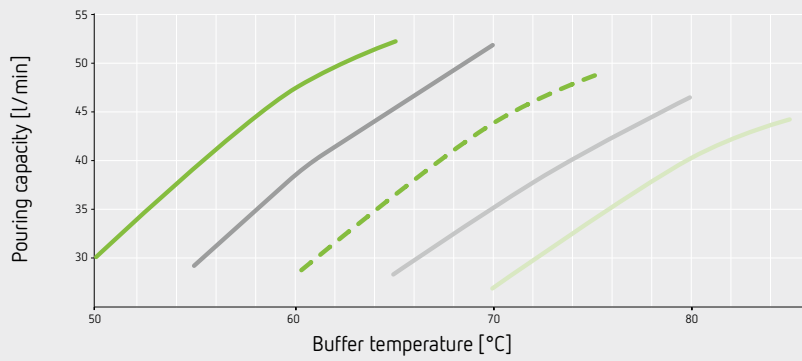

### Reflex Hydroflow XL

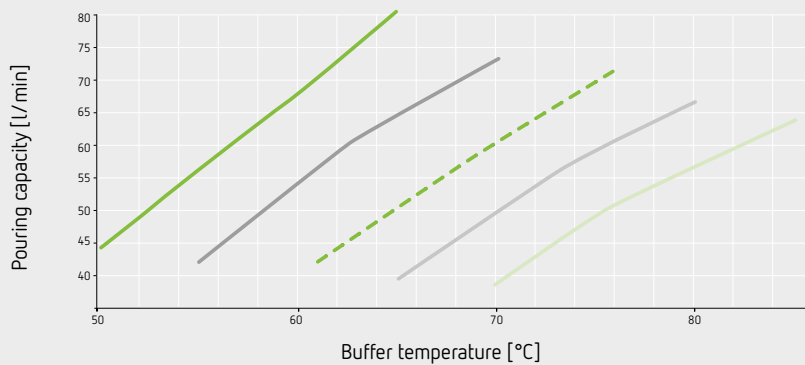

# Product range Small manifolds

## Small manifolds

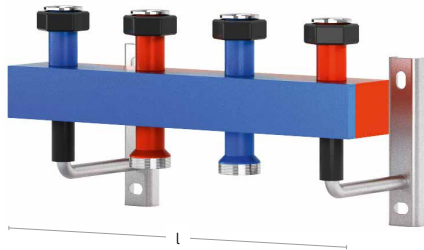

Small manifolds 80/60

### Technical Features

- combined flow and return manifold, consisting rectangular tube with adjoining chambers divided by sinusoidal dividing wall made from mild steel sheet S235
- 100 % factory-checked for leak tightness and primed
- with thread or union nuts
- packed as a set
- type 80/60: with EPP insulation and wall mount
- type 120/80: with EPP insulation
- permissible operating temperature -10 °C – 110 °C
- permissible operating overpressure 0 bar – 4 bar
- ideal for use with: maintenance box

Type	Art. No.	Heating circuits [pcs.]	Connection generator	Connection heating circuit	$V_{max}$ [m <sup>3</sup> /h]	Output at $\Delta T 20\text{ °K}$ [kW]	Length l [mm]
Nozzle spacing 125 mm							
80/60	4208563	2	G 1½"	G 1½" coupling nut	3.0	70.00	475
80/60	4208565	3	G 1½"	G 1½" coupling nut	3.0	70.00	725
80/60	4208851	4	G 1½"	G 1½" coupling nut	3.0	70.00	975
80/60	4208852	5	G 1½"	G 1½" coupling nut	3.0	70.00	1,225

# Storaflow

## Key benefits

### Construction and function

- Minimal thermal mixing inside the hot water storage tank thanks to stratification by means of stratification charging pipework and stratification separator
- Extensive features with 2" connections for high through-flow quantities
- Perfect for use on heat pumps as well as hybrid applications

### Easy installation

- Easily extended to the system thanks to connection of a compact manifold
- Rapid installation with 90° connection dimension for easier installation at the preferred location

### Flexible usage

- Energy saving due to efficient operation and rapid reaction of the heating element due to optimum flange position
- Large number of system configuration options for new builds and existing stock, for example, due to hybrid operation of a heat pump and a conventional boiler
- Multivalent operation possible using a heating element and a heating spiral and connecting two heat generators in hybrid operation
- Support for a 65% regenerative energy carrier in the lower standby section of the hot water storage tank by connecting regenerative energy sources using heating spirals and innovative connection patterns

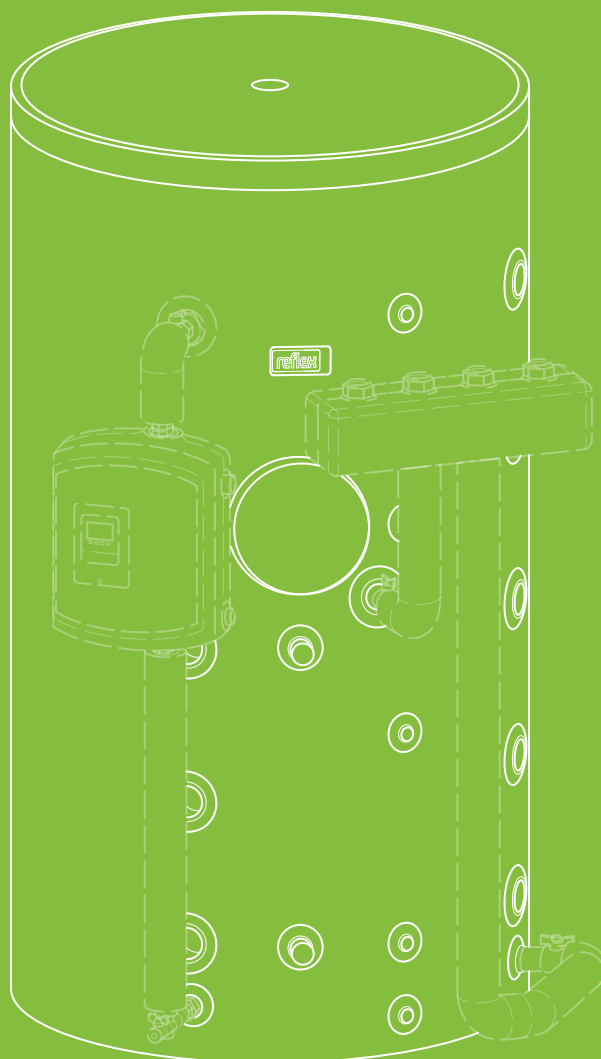

# Construction, function, application

## Storaflow temperature stratification in conjunction with Reflex Hydroflow

Storaflow is particularly suitable for use with a Reflex Hydroflow freshwater station and manifolds. There are versions with a flange and internal heat exchanger for connection to external energy sources.

1. The series of 2" connectors for heat generators and heat consumers are offset vertically by 90° and arranged as charging and discharging ports, five on each side with an additional 2" central connection.
2. Four Rp ½ threaded connections for sensor sleeves, thermometers and other equipment are provided between these series of connectors, also arranged vertically.
3. In addition to this, each of the 2" connectors has a parallel 1¼" port on each side for return stratification in conjunction with a perforated internal stratification charging pipework.
4. The internal stratification separator plate complies with DIN 24041.
5. An Rp ¾" connection is provided at the base of the hot water storage tank for filling and emptying.
6. Flange for installing electric heating.
7. Bare-tube heat exchanger with flow and return ports to the tube bundle heating surface.
8. Storage container made from S235JR steel, bare metal internally, with external corrosion protection. Buffer tanks up to 800 litres insulated with removable 120 mm insulated top cover and 120 mm insulated jacket. Buffer tanks from 800 litres insulated with removable 120 mm insulated top cover and 150 mm insulated jacket. Fleece insulation in accordance with DIN 4102-1, material class B2 All hot water storage tanks are supplied insulated.
9. Hot water storage tanks have lugs on the top surface.

The hot water storage tanks are available in energy efficiency class C. The standing losses are determined on externally certified test rigs.

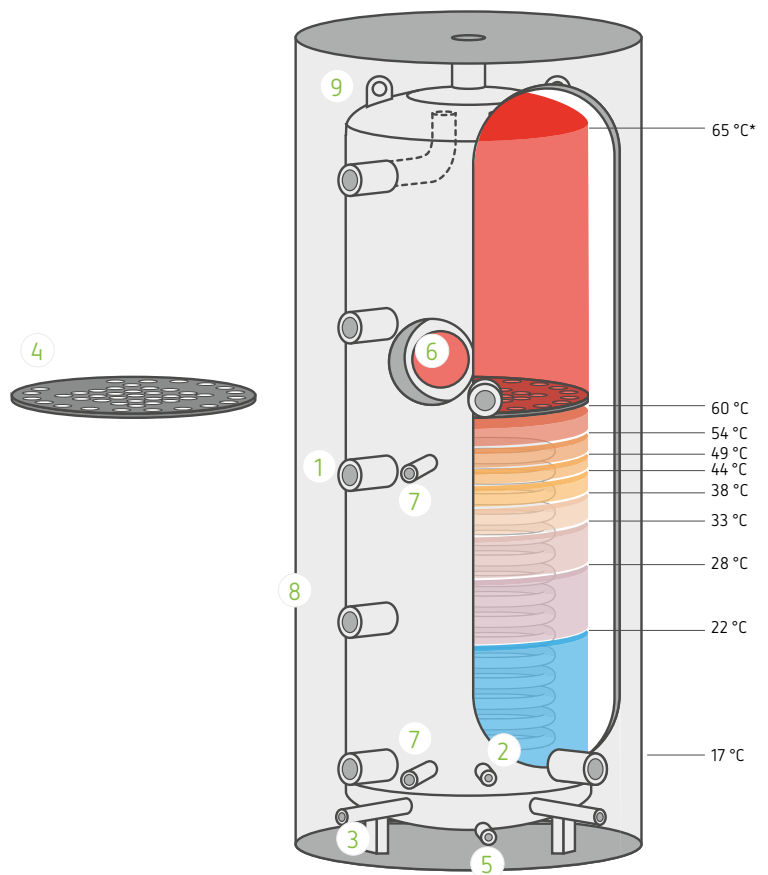

\* The temperature values are taken from a practical example. The value can vary depending on the application.

The stratification minimises thermal mixing inside the hot water storage tank; greater storage efficiency is therefore achieved and a correspondingly high flow temperature is available at the required location. The heating water is therefore efficiently available at the required temperature at the correct point. This also avoids unnecessary overloading of the hot water storage tank.



# Product range Storaflow

Storaflow

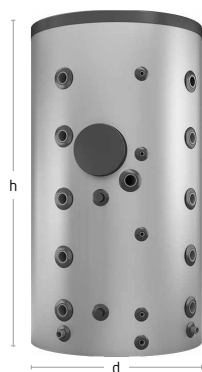

SH 500 H/F/1\_C – SH 2000 H/F/1\_C

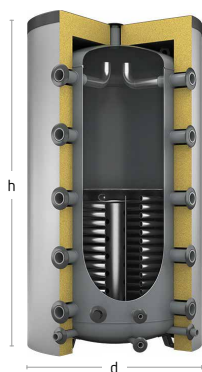

SH 500 H/F/1\_C – SH 2000 H/F/1\_C cross section

### Technical Features

- Storaflow hot water storage tank for storing heating water and central heating backup
- potable water heating using the continuous flow principle with a Reflex Hydroflow mains water station
- tank not treated inside, plastic-coated outside
- insulation preinstalled
- fleece insulation with foil jacket
- permissible operating overpressure:
  - 500 – 1,000 l 3 bar
  - 1,500 – 2,000 l 6 bar
  - solar or solid fuel support by means of internal heat exchanger 10 bar
- permissible operating temperature:
  - tank 95 °C
  - internal heat exchanger 110 °C

## Type overview

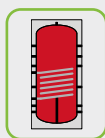

### SH...H/F/1

buffer tank with one bare-tube heat exchanger and a flange for the installation of an electric heater

#### insulation

up to 800 l: 120 mm fleece insulation with foil jacket, removable  
 from 1000 l: 150 mm fleece insulation with foil jacket, removable

Type	Art. No.	EEC <sup>1</sup>	Volume	Connection	Heating surface	Ø d	Height	Weight
	silver		[l]	c	top   solar [m <sup>2</sup> ]	without   with insulation [mm]	[mm]	[kg]
SH 500 H/F/1_C	7938000	C	500	Rp 2"	–   1,90	597   840	1,986	136.00
SH 800 H/F/1_C	7938100	C	800	Rp 2"	–   2,60	790   1.010	1,859	168.00
SH 1000 H/F/1_C	7938200	C	1,000	Rp 2"	–   3,20	790   1.090	2,149	190.00
SH 1500 H/F/1_C	7938300	C	1,500	Rp 2"	–   3,80	1.000   1.300	2,140	276.00
SH 2000 H/F/1_C	7938400	C	2,000	Rp 2"	–   4,40	1.200   1.500	2,161	394.00

<sup>1</sup> Energy efficiency class

## Storaflow accessories



### EFHR

- electrical auxiliary heating
- approved for continuous operation
- suitable for these types:
  - Storatherm Aqua
  - Storatherm Aqua Solar
  - Storatherm Aqua Load
  - Storatherm Aqua Heat Pump
  - Storatherm Heat HF.../R
  - Storaflow
- easy integration via the tank's maintenance opening
- up to 10.0 kW LK 150 mm
  - ≤ 500 litres storage volume for potable water
  - buffer tank of type HF.../R and H.../R
- from 16.0 kW LK 225 mm
  - > 500 litres tank volume for potable water
- 3 power levels, reversible connections
- with temperature controller –95 °C
- safety temperature limiter 110 °C
- electrical connection (on-site) 400V/50 Hz
- incl. flange and seal

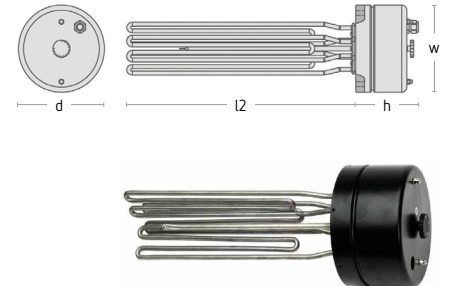

### Pipe connection set

- Plug & Play installation of single Reflex Hydroflow stations on Storaflow hot water storage tank with pre-assembled pipe connection set
- incl. shut-off valves and drain valve
- incl. seals and insulation material

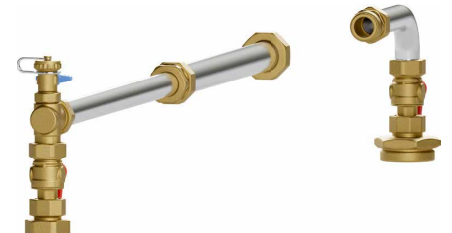

Type	Art. No.	Weight [kg]
<b>EFHR flange-type electric heating element</b>		
EFHR 2,5	9118710	2.94
EFHR 4,0	9116314	3.54
EFHR 6,0	9116315	4.80
EFHR 8,0	9116316	5.00
EFHR 10,0	9116317	5.00
EFHR 16,0	9116501	10.50
EFHR 19,0	9116502	11.00
EFHR 25,0	9115569	11.00
EFHR 35,0	9126720	13.44
<b>Pipe connection set</b>		
XS/S/M	9583602	3.60
L	9583603	2.50
<b>flange adapter</b>		
DN 110/DN 180	5402400	4.00

# Your notes

A series of horizontal dotted lines for writing notes.

# Selection and calculation

## Possible combinations

Reflex Hydroflow with Storaflow Heat Solar, manifold and accessories

		Storaflow Heat Solar				
		500 H/F 7938000	800 H/F 7938100	1,000 H/F 7938200	1,500 H/F 7938300	2,000 H/F 7938400
Reflex Hydroflow	XS—CU 9583531	✓	✓	✓	✓	✓
	XS—SST 9583532	✓	✓	✓	✓	✓
	S—CU 9583533	✓	✓	✓	✓	✓
	S—SST 9583534	✓	✓	✓	✓	✓
	M—CU 9583535	✓	✓	✓	✓	✓
	M—SST 9583536	✓	✓	✓	✓	✓
	L—CU 9583538	×	✓	✓	✓	✓
	L—SST 9583539	×	✓	✓	✓	✓
	XL—CU 9583541	×	✓	✓	✓	✓
	XL—SST 9583542	×	✓	✓	✓	✓
	Cascade					
	Single station					
80/60 small manifolds	2 heating circuits 4208563	✓	✓	✓	✓	✓
	3 heating circuits 4208565	×	✓	✓	✓	✓
	4 heating circuits 4208851	×	×	✓	✓	✓
	5 heating circuits 4208852	×	×	×	✓	✓

Accessories												
Circulation unit		Cascade pipework		Return stratification		Ball valve set		Cascade ball valve		Free-flow valve	Heating water mixer	BMS Module
S/M 9583553	L/XL 9583556	M 9583554	L 9583558	DN 32 M 9583555	DN3 2 L 9583559	XS/S/M 9583551	Cascade pipework M 9583552	L 9583557	DN 32 5/4" XL 9583562	DN 32 5/4" XL 9583561	9583563	9583608
×	×	×	×	×	×	✓	×	×	×	×	✓	×
×	×	×	×	×	×	✓	×	×	×	×	✓	×
✓	×	(✓)	×	✓	×	✓	✓	×	×	×	✓	✓
✓	×	(✓)	×	✓	×	✓	✓	×	×	×	✓	✓
✓	×	✓	×	✓	×	✓	✓	×	×	×	✓	✓
✓	×	✓	×	✓	×	✓	✓	×	×	×	✓	✓
×	✓	×	✓	×	✓	×	×	✓	×	×	×	✓
×	✓	×	✓	×	✓	×	×	✓	×	×	×	✓
×	✓	×	×	×	✓	×	×	×	✓	✓	×	✓
×	✓	×	×	×	✓	×	×	×	✓	✓	×	✓
✓	×	✓	✓	✓	✓	×	✓	✓	✓	×	×	✓
✓	✓	×	×	✓	✓	✓	×	×	×	✓	✓	✓

✓	can be combined
×	cannot be combined
(✓)	limited possible combinations

## Possible combinations

Storaflow Heat Solar with accessories

		Storaflow Heat Solar				
		500 H/F	800 H/F	1,000 H/F	1,500 H/F	2,000 H/F
Storaflow Heat Solar accessories	EFHR 2.5 – 10 kW	✓	Flange adapter required			
	EFHR 16 – 25 kW	×	✓	✓	✓	✓
	EFHR 35 kW	×	×	×	✓	✓
	Flange adapter	×	✓	✓	✓	✓
	Seal	DN 110	DN 180	DN 180	DN 180	DN 180
	Flange (closed)	DN 110	DN 180	DN 180	DN 180	DN 180

## Configuring using Reflex Solutions Pro



The proven Reflex Solutions Pro configuration tool makes it easy to configure a freshwater station.

In just a few clicks, the user has a complete system including buffer tank and discharge side protection from the expansion vessel. The intuitive interface allows planners and specialist tradespeople to produce custom solutions in no time at all. Simply enter the required building type and the details of the tapping points, and Reflex Solutions Pro automatically calculates the hot water requirement and selects the optimum components. From avoiding potential stagnation to protection from bacteria and germs.

There are already more than 10,000 registered RSP users benefiting from documentation, BIM data and prefabricated solutions.

→ Find out more on [page 42](#)

Our configuration software



Reflex Solutions Pro  
[rsp.reflex.de/en](http://rsp.reflex.de/en)

## Configuration in accordance with DIN 1988-300

Configuring a freshwater station in accordance with DIN 1988-300 has a set sequence:

- 
- 1. Select small or large system**  
Determine the size of the system in accordance with the DVGW (German Technical and Scientific Association for Gas and Water) Code of Practice W551.
  - 2. Calculate the water quantity**  
First, determine the required water quantity based on the building requirements. This includes factors such as the number of users, the type of usage (e.g. residential or commercial) and type of usage (e.g. potable water or sanitary).
  - 3. Calculate the hot water requirement**  
The hot water requirement is calculated based on the water quantity determined, taking the utilisation factor for the building type in consideration. This includes factors such as the target buffer temperature and the temperature differential between the hot and cold water.
  - 4. Select the components**  
The appropriate components for the freshwater station are selected based on the hot water requirement. This includes, amongst other things, the buffer tank, the freshwater station, the intrinsically safe pressure maintenance for the primary and secondary sides, as well as the accessories.
  - 5. Documentation**  
Documentation is produced at the end of the process which contains all the relevant information on the configuration of the freshwater station in accordance with DIN 1988-300. This includes the calculations, component selection, and any additional requirements.

Care should be taken that the configuration of a freshwater station in accordance with DIN 1988-300 is completed by **qualified skilled personnel** as it must comply with specific standards and provisions in order to ensure a safe and efficient supply of water.



# Selection and calculation

## Output capacities of the individual stations

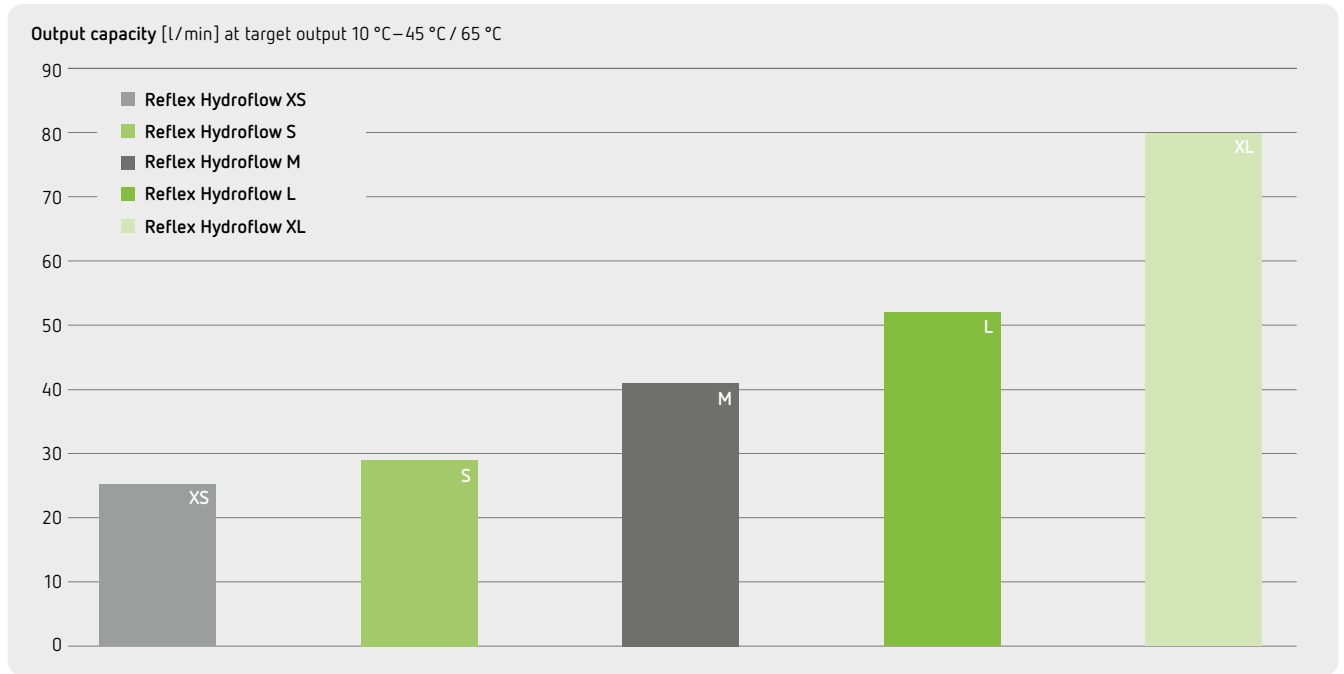

## Cascade output capacities

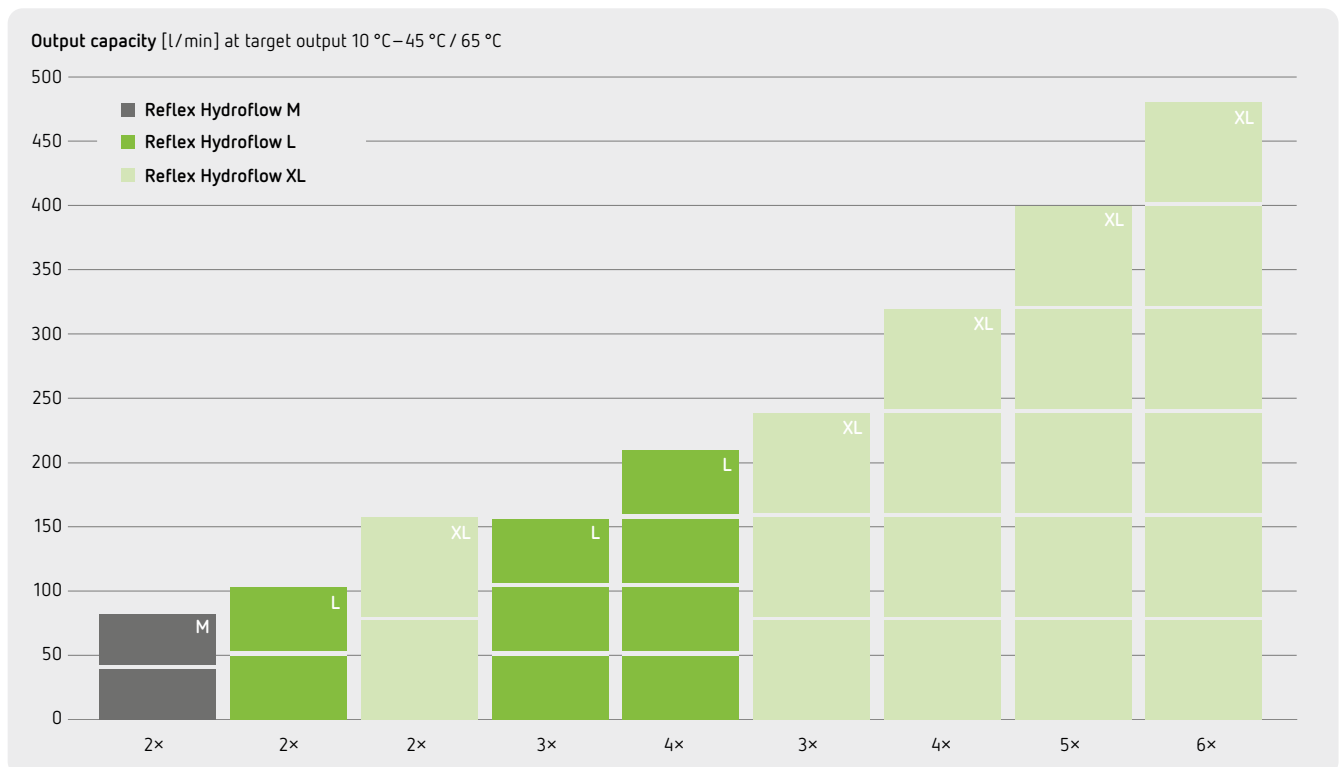

# Your notes

A series of horizontal dotted lines for writing notes.

# Installation and commissioning

## Installation

The Reflex Hydroflow can be installed on a wall or on the hot water storage tank.

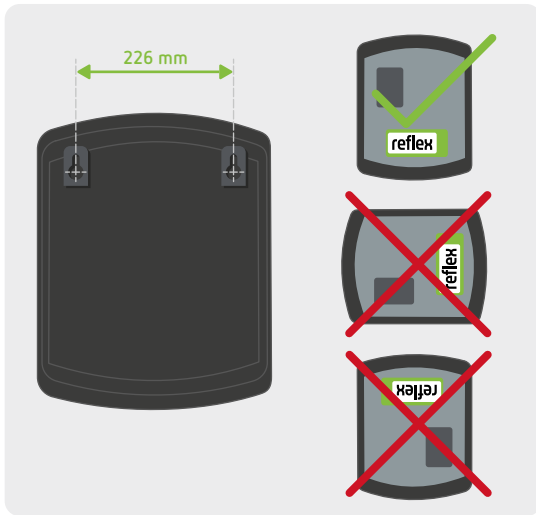

Wall mounting with screw connection

- The Reflex Hydroflow must be installed using appropriate fixings for the substrate with the legible Reflex logo horizontal.
- Connect to the on-site pipework using a screw connection with a flat gasket.
- In the best case scenario, the on-site pipeline routes are to be kept to a minimum. Select suitably sized pipework material and diameters in accordance with the state of the art and the local situation.

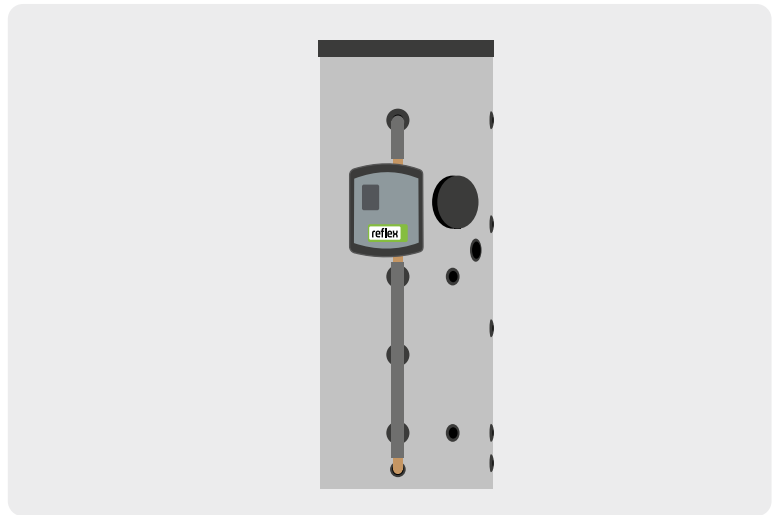

Hot water storage tank installation with a pipe connection set

- Fresh water stations can be flexibly attached to the right or left of the buffer tank.
- The pipe connection set → p. 22 provides the best hot water storage tank installation solution: rapid installation using prefabricated connection set with insulation and drain and shut-off ball valves.
- Connect to the on-site pipework using a screw connection with a flat gasket.
- Fit the upper part of the pipe set to the hot water storage tank. Then hang the Reflex Hydroflow on the pipe set. The lower return pipe can be adjusted to the required length on site.

## Installation options

Reflex Hydroflow with Storaflow Heat Solar, manifold and accessories

		Installation on the hot water storage tank	Storaflow Heat Solar				
			500 H/F	800 H/F	1,000 H/F	1,500 H/F	2,000 H/F
Reflex Hydroflow	XS	To the left	✓	✓	✓	✓	✓
		To the right	✓	✓	✓	✓	✓
		Pipe connection set	Hydroflow XS				
		Wall mounting	✓	✓	✓	✓	✓
	S	To the left	✓	✓	✓	✓	✓
		To the right	✓	✓	✓	✓	✓
		Pipe connection set	Hydroflow S				
		Wall mounting	✓	✓	✓	✓	✓
	M	To the left	✓	✓	✓	✓	✓
		To the right	✓	✓	✓	✓	✓
		Pipe connection set	Hydroflow M				
		Wall mounting	✓	✓	✓	✓	✓
	L	To the left	×	✓	✓	✓	✓
		To the right	×	Maintain a distance of 180 mm between the hot water storage tank and the wall for the manifold		✓	✓
		Pipe connection set	Hydroflow L				
		Wall mounting	✓	✓	✓	✓	✓
	XL	To the left	×	✓	✓	✓	✓
		To the right	×	Maintain a distance of 180 mm between the hot water storage tank and the wall for the manifold		✓	✓
		Wall mounting	✓	✓	✓	✓	✓
		80/60 small manifolds	2 heating circuits 4208563	To the left	Manifold extends beyond the base of the hot water storage tank 210 mm	110 mm	✓
Centred	✓			Reflex Hydroflow XS – S only: mounting options to the left and right mount Reflex Hydroflow L – XL to the left		✓	
To the right	Manifold extends beyond the base of the hot water storage tank 210 mm			110 mm	✓	✓	
Wall mounting	✓			✓	✓	✓	



Mounting option possible



Mounting option not available

## Hydraulic connection

- Connect the cold water in accordance with DIN 1988. Ensure the safety valve cannot be shut off. The Reflex Hydroflow must always be operated via a buffer tank.
- We recommend a through-flow expansion vessel is included on the secondary side.
- The first step is to open the furthest distant tapping point on the secondary side. The system must be slowly filled with potable water; careful venting is required.
- Vent the primary side using the integral manual vent, and by tapping on the secondary side.

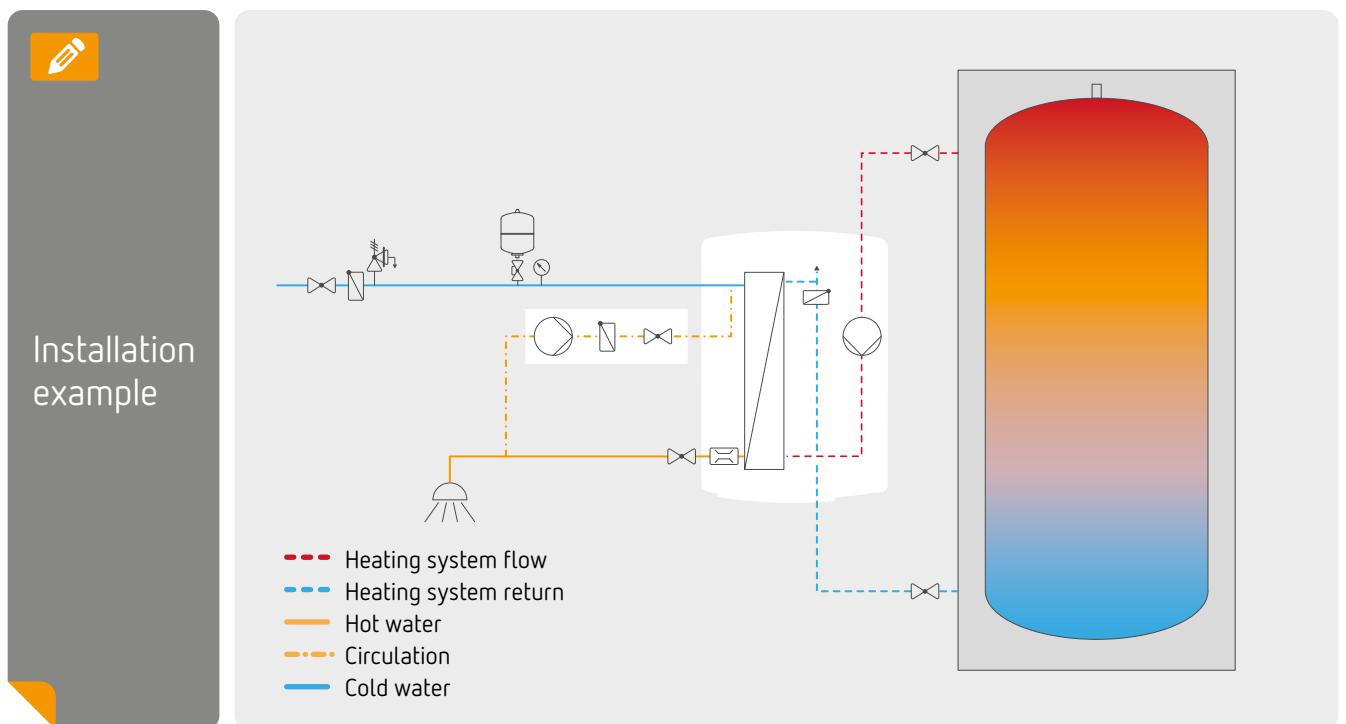

## Direction of flow

It is important to ensure the freshwater station is connected correctly to the system. As a rule of thumb, the heat exchanger is always on the left and the pump on the right.

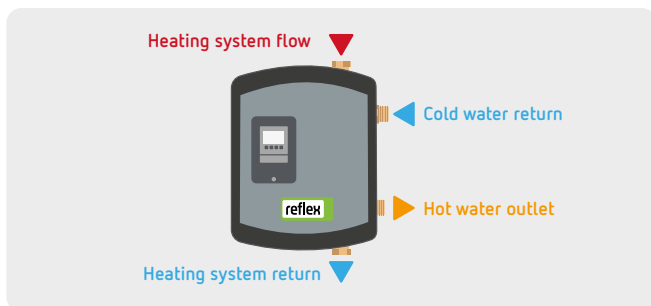

### Reflex Hydroflow XS, S, M

On the small station sizes, XS, S, and M, the secondary side runs from the cold water inlet top right to the hot water outlet, bottom right.

The heating system flow is connected to the upper inlet on the freshwater station. The heating system return is via the lower outlet.

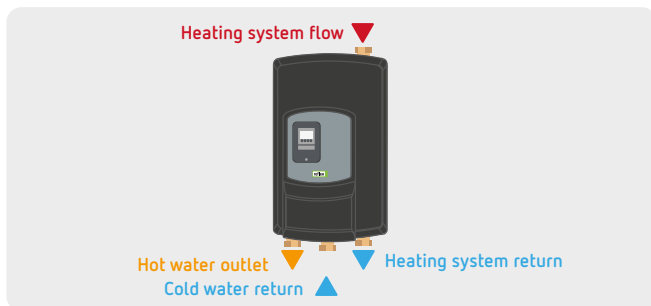

### Reflex Hydroflow L, XL

On the large stations, L and XL, the cold water flow on the secondary side is lower middle and hot water outlet lower left.

Connect the heating system flow to the upper right and the heating system return to the lower right.

## Commissioning

Always check the system for leaks before commissioning. The following points are important when commissioning:

1. Always inspect the installation.
2. The correct physical and electrical installation of both temperature sensors must be checked as well as all inlet and outlet connections.
3. The regulator can then be switched on.
4. The regulator must be set in accordance with the installation and operating instructions.
5. Then open the ball valves on the primary side. Open the lower ball valve first.

6. Correct pump usage must be checked as well as the hot water preparation at the hot water outlet.
7. Finally, check the optional circulation and cascade functions.

The system must only be filled with clean potable water in accordance with DIN 1988. The air is forced out of the pipework by the slight increase in pressure. Only fill the heating system including the Reflex Hydroflow primary side with prepared water in accordance with VDI 2035. The system must be completely vented. Tapping flows > 56 l/min should be avoided as these will destroy the sensor and cause the freshwater station to fail in the long term.

### Bivalent system without sensors

The Storaflow buffer tank as the central element of a system, operated by a heat pump, another heat generator and with optional solar thermal support.

Plus centralised hot water preparation using a Reflex Hydroflow fresh water station.

A wide range of accessories such as pressurisation and make-up fittings are available from Reflex.

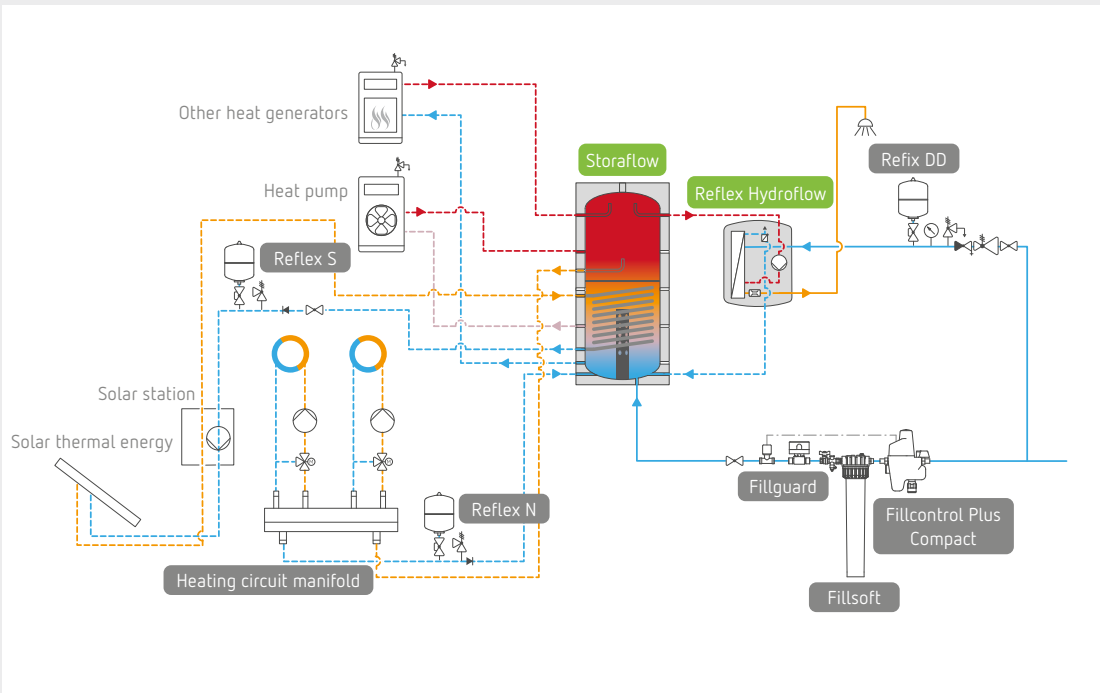

### Monovalent system without sensors

The Storaflow buffer tank as the central element of a system, operated by a heat pump with optional solar thermal support.

In addition, centralised hot water preparation using a Reflex Hydroflow fresh water station.

A wide range of accessories such as pressurisation and make-up fittings are available from Reflex.

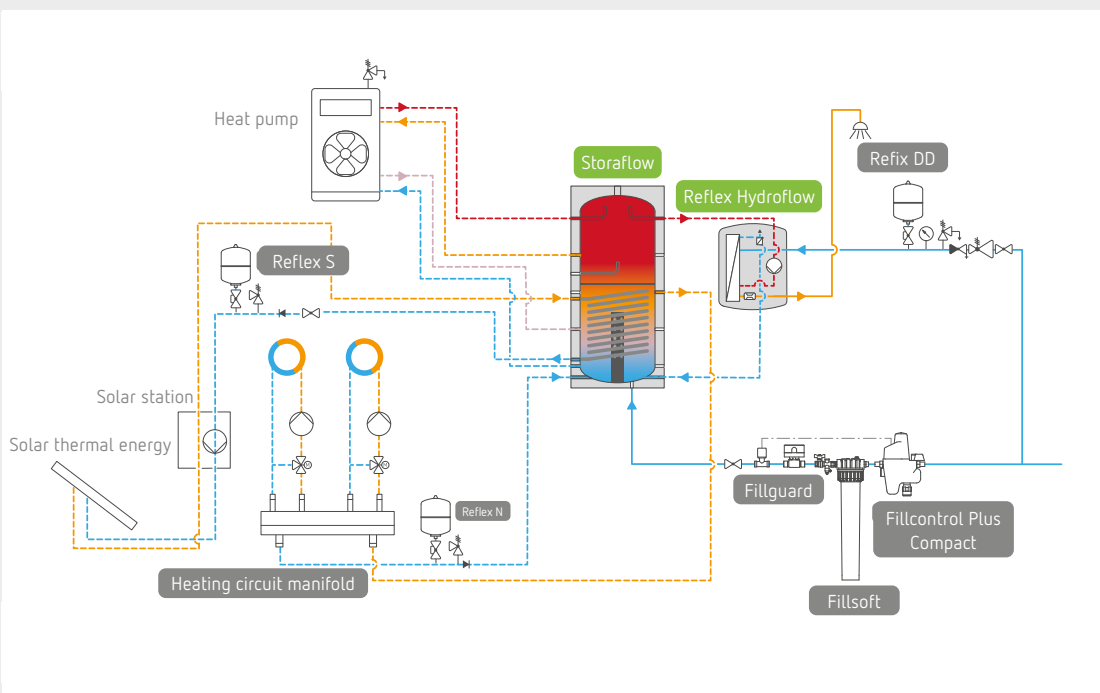

Storaflow cascade in-line storage tank 3x, Reflex Hydroflow & return flow stratification

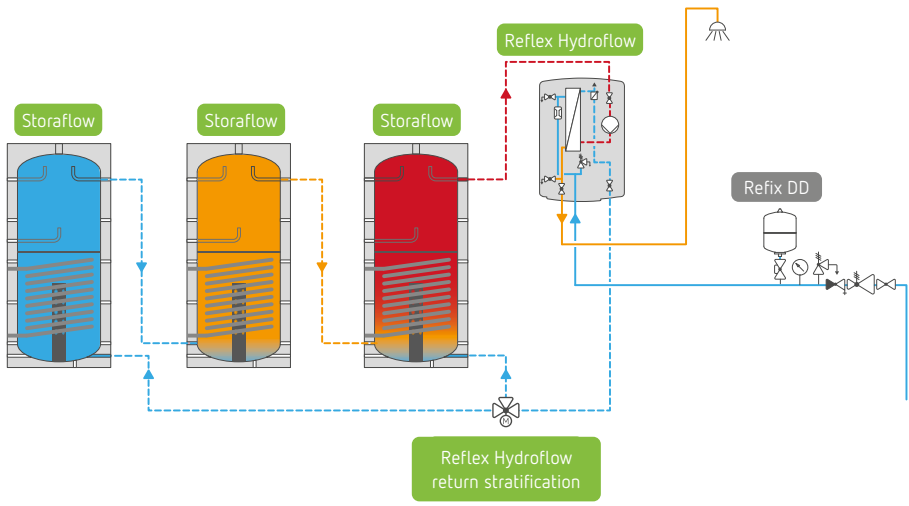

The Storaflow buffer tank is connected in a triple cascade, with return stratification.

Plus centralised hot water preparation using a Reflex Hydroflow fresh water station.

Storaflow cascade parallel storage tank 3x with Reflex Hydroflow cascade 2x

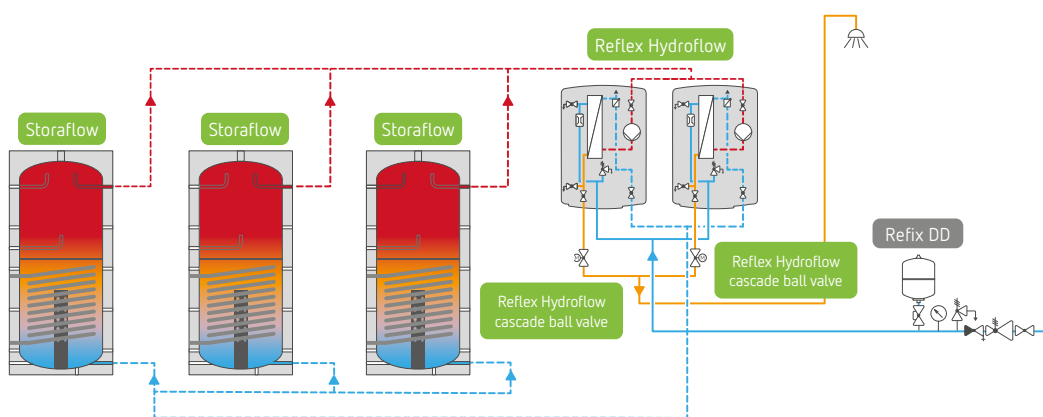

The Storaflow is connected as a triple cascade and parallel buffer tank.

Plus centralised hot water preparation using a Reflex Hydroflow fresh water station cascade.

# Flexible overall system from Reflex

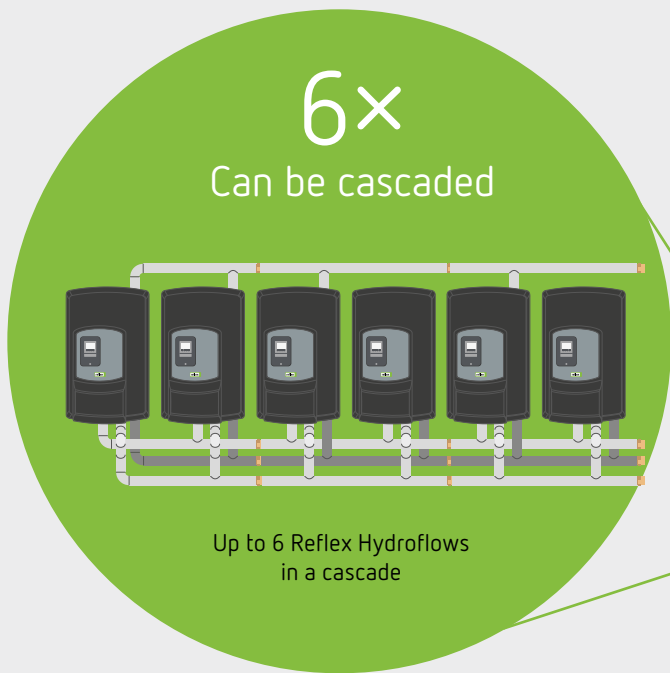

**BMS module**  
Optimum connectivity

This block shows two components: a green BMS module with a screen and a silver BMS module. A dashed line connects this block to the main Reflex Hydroflow unit.

**Reflex Hydroflow**



**Circulation set**  
Maximum hygiene due  
to continuous circulation

This block shows a circulation set consisting of a brass valve with a red handle and a red pressure gauge. A green arrow points from this block to the main Reflex Hydroflow unit.

**Connection set**  
Easy installation  
Fewer errors

This block shows a connection set consisting of a brass valve with a red handle and a red pressure gauge. A green arrow points from this block to the main Reflex Hydroflow unit.

2-5  
heating circuits  
can be connected



Storaflow

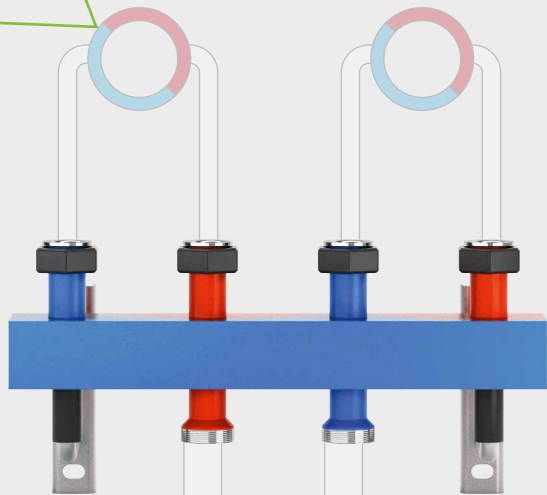

Manifold

Tank volume up to  
**2000 l**  
Tank volume

# Cascading

Cascading is the connection of several modules which allows greater output as well as higher modulation areas to be achieved. At the same time, it allows greater operating safety as at least one other module is available if one fails. Where a single station cannot provide adequate output, it makes sense to install a cascade if the spread of the minimum and maximum requirements is too great for one station or if the building

structure has a high operating safety requirement, such as in schools, hospitals or multi-occupancy housing.

When cascading, care should always be taken that the correct cabling and connections are selected so that uniform through flow is ensured. The cascading must also match the relevant load case.

## Cascading a freshwater station

The Reflex Hydroflow M, L and XL from the Reflex portfolio can be cascaded. The smaller M station can be cascaded twice, the L station four times, and the XL station 6 times.

However, all stations in the cascade must be the same size. Cascading is only possible using wall-mounted stations and not the version mounted on a hot water storage tank.

The motor ball valve is closed as standard and is opened when the tapping volume exceeds the output of a single station in order to start the cascade circuit. The stations work in a master-slave mode with one station as the master.

Reflex offers the twin pipework set as an accessory for the cascade pipework.

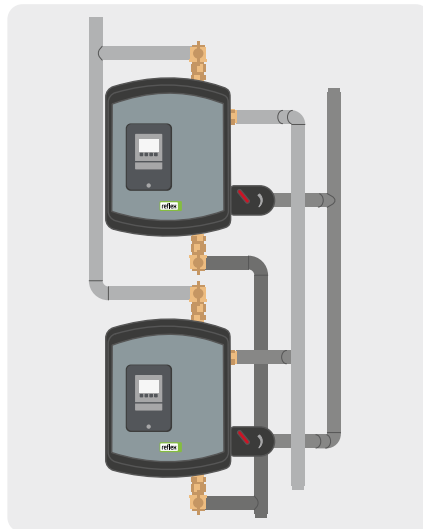

Vertical cascade pipework for two Reflex Hydroflow M

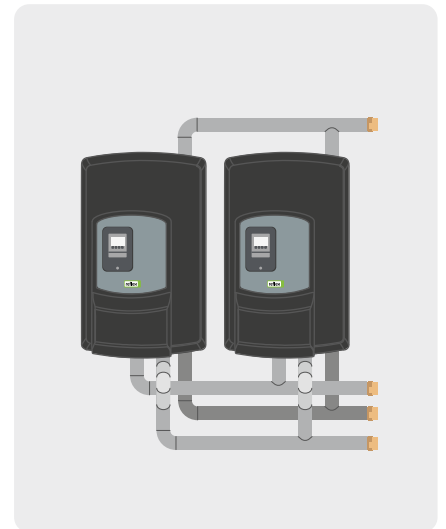

Horizontal cascade pipework to the right for two Reflex Hydroflow L

## Cascading—installation

### When installing, ensure:

1. Each station has a cascade valve.
2. The circulation line is installed outside the stations and the electrical connection is installed in accordance with the regulator instructions.
3. Depending on the self-adjusting return temperature, the return is stratified by a three-way valve in the buffer tank. An additional temperature sensor is required in this instance.

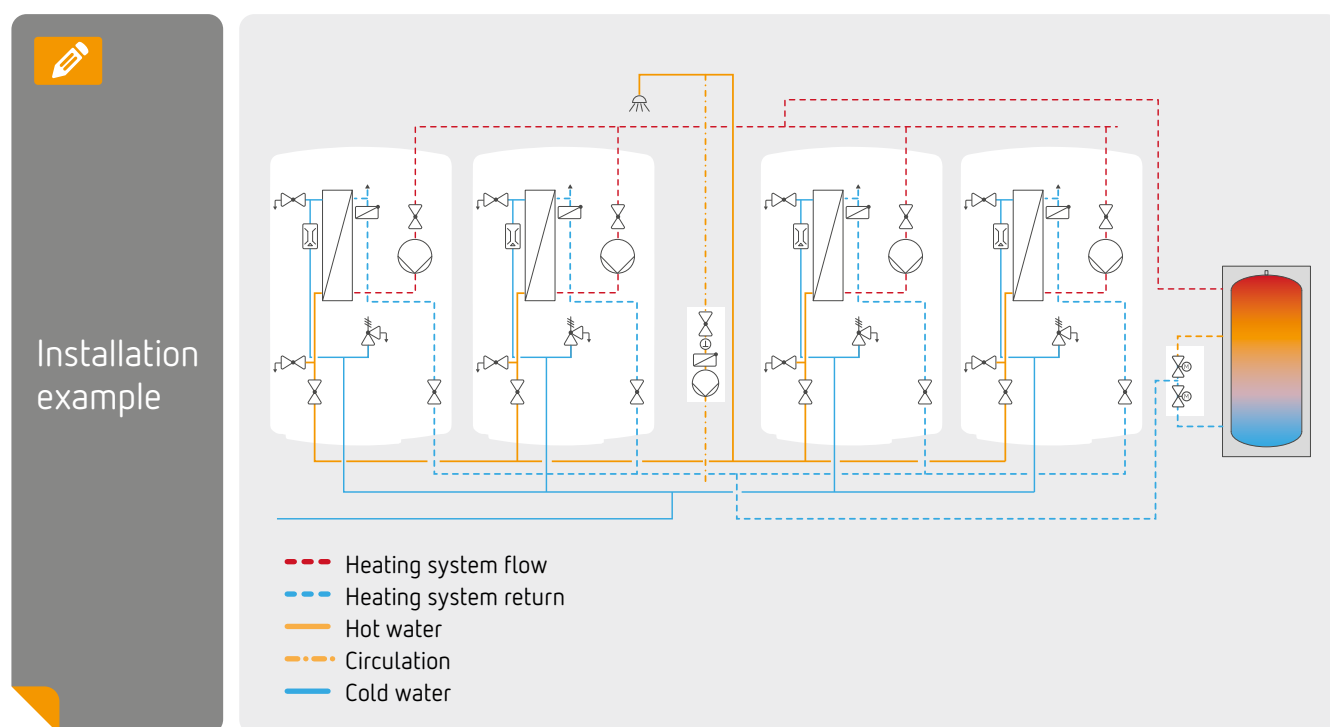

# Reflex Hydroflow performance diagrams

## 2-fold cascading

2 × Reflex Hydroflow M

Hot water temperature

- 45°C
- 50°C
- 55°C
- 60°C
- 65°C

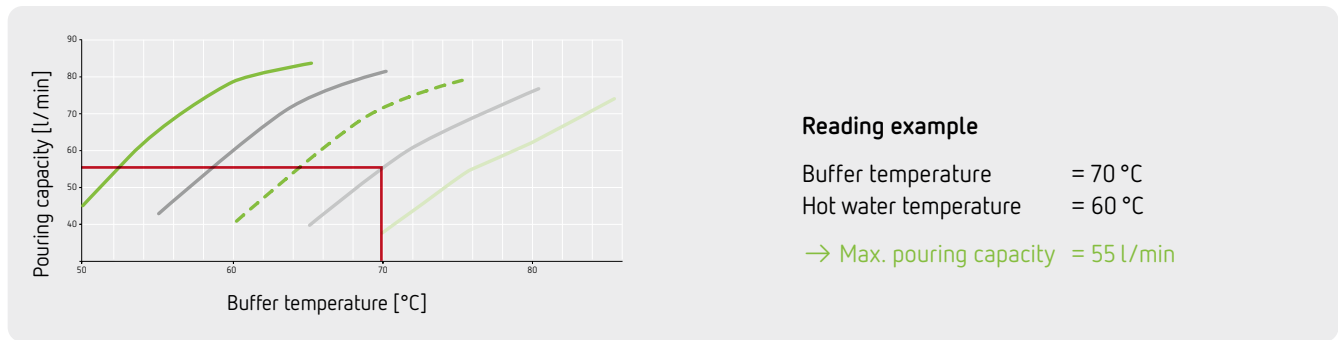

2 × Reflex Hydroflow L

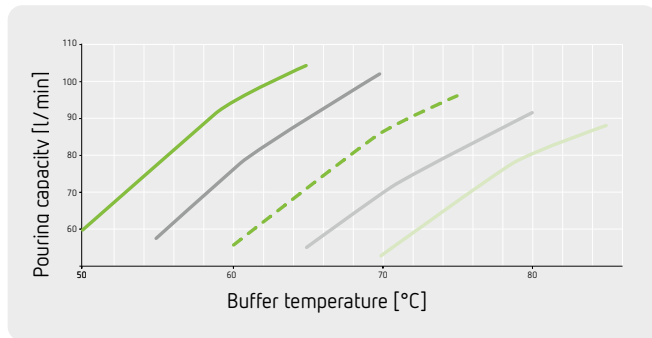

2 × Reflex Hydroflow XL

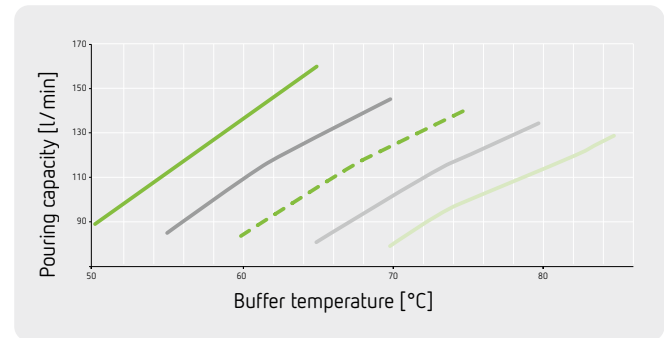

## 3-fold cascading

3 × Reflex Hydroflow L

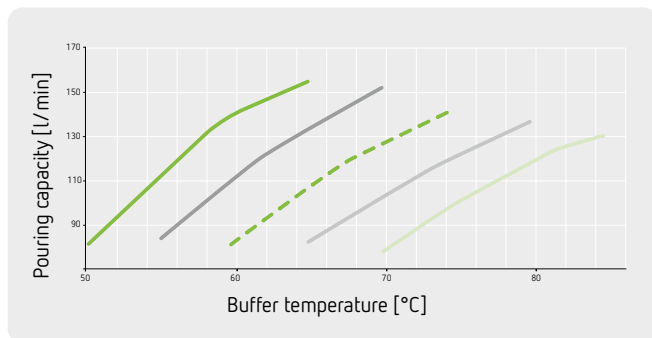

3 × Reflex Hydroflow XL

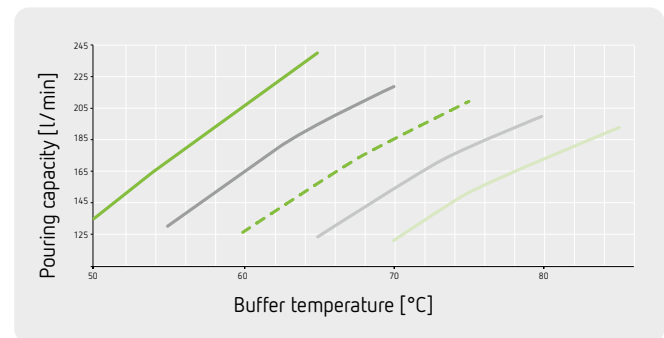

## Reflex Hydroflow performance diagrams

### 4-fold cascading

4 × Reflex Hydroflow L

Hot water temperature

45°C

50°C

55°C

60°C

65°C

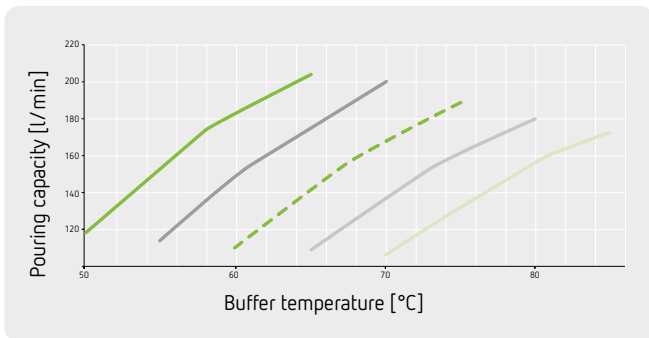

4 × Reflex Hydroflow XL

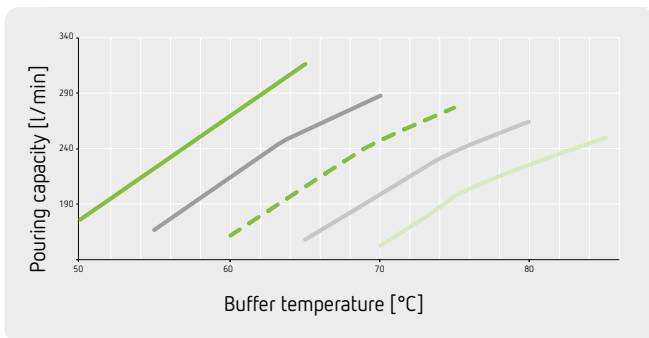

### 5-fold cascading

5 × Reflex Hydroflow XL

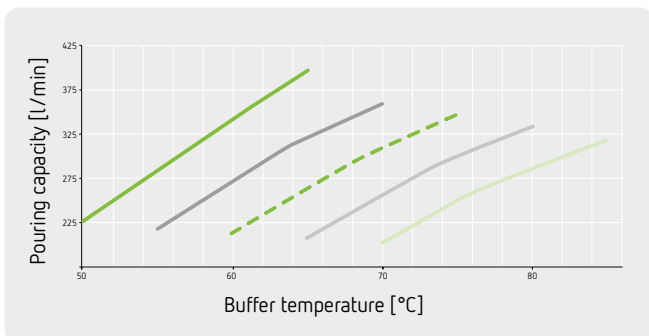

### 6-fold cascading

6 × Reflex Hydroflow XL

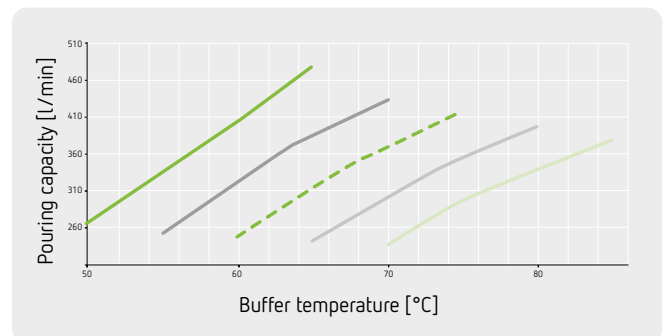

# Reflex added value

## Our digital services



### Reflex Solutions Pro —

#### complete product solutions quickly and easily

The next generation of the proven configuration tool allows products from the entire Reflex portfolio to be individually compiled and configured to suit a specific system, irrespective of size — from a single-family home to residential buildings

and industrial premises. Whether a single product or a complete system, just choose the application, then enter the relevant system parameters, Reflex Solutions Pro works out the appropriate configuration quickly and precisely. With one click, you can download the complete documentation such as product data, tender texts and BIM data.

Start designing your configuration now for free:

 [rsp.reflex.de/en](https://rsp.reflex.de/en)

## Reflex Training — expertise gives us the edge



Close to our headquarters in Ahlen, professional craftsmen, planners and operators gear up to meet the challenges posed by heating and hot water supply in modern building technology. From installation and planning to consulting and technical operation, the Reflex Training Centre and its team aligns its programme to those partners who want to learn more about technology, standards and service from the horse's mouth.

Newly acquired expertise is put into practice, refined and experienced straight away on Reflex systems in a former manor house that has been refurbished to modern-day standards in the German region of Westphalia. Realistic simulations and a comprehensive portfolio of systems help to put the content learned to practical use, skilfully combining theory with practical aspects. The Reflex4Experts training courses are now also available online, for example, as webinars for PC, tablet or smartphone, and include short, interesting learning units on current and exciting topics that can be easily followed in the office, at home or on the road.

More information is available at [www.reflex4experts.com/en](http://www.reflex4experts.com/en)

Reflex Training Center

+49 2382 7069-9581  
[seminare@reflex.de](mailto:seminare@reflex.de)



## Our performance promise — Reflex After Sales & Service

Supply technology systems are becoming increasingly complex. This is true for the technology as well for documentation and testing requirements. With Reflex After Sales & Service, you remain in good hands after your purchase. Our years of expertise specialising in the Reflex product world ensure the full safety and functionality of your system.

- Expertise and many years of experience with all Reflex products
- Qualified personnel with expertise in the latest products and guidelines
- Compliance with statutory regulations and therefore also with liability and warranty provisions
- Systems optimally adapted for maximum efficiency and functionality

You can find more information about all our services at [www.reflex-winkelmann.com/en/services/after-sales-and-service](http://www.reflex-winkelmann.com/en/services/after-sales-and-service)



### Warranty extension to five years

From now on, you can register your system after it has been commissioned by us or by a service partner certified by us. If you enter into a maintenance contract at the same time, you are entitled to a warranty extension to five years. Take advantage of this opportunity easily at [www.reflex-winkelmann.com/en/services/after-sales-and-service/warranty](http://www.reflex-winkelmann.com/en/services/after-sales-and-service/warranty) on our home page or simply use the sticker on your product to access registration.

Registration is not only possible at the time of commissioning but is also valid for all systems with a manufacturing date of up to six months from the year of manufacture 2020.

With the new online service order, we are optimising the service for our customers even further. It takes just a few clicks to create the order form, and it can be processed directly in our system. This makes our service even faster and more customer friendly.



Technical hotline

+49 2382 7069-9546  
aftersales@reflex.de



Factory service centre

+49 2382 7069-9505  
aftersales@reflex.de



Commercial processing

+49 2382 7069-7505  
aftersales@reflex.de



## Discover Reflex with augmented reality



1 Scan QR-Code.  
[reflex.de/en/city](https://reflex.de/en/city)



2 Download the  
Reflex Smart City app



3 Scan the title of this  
brochure and explore

### Always up to date

Further product literature and materials can be downloaded at or hard copies ordered from [www.reflex-winkelmann.com/en/services/documents-and-videos](https://www.reflex-winkelmann.com/en/services/documents-and-videos)



Thinking solutions.

Reflex Winkelmann GmbH  
Gersteinstrasse 19  
DE-59227 Ahlen  
+49 2382 7069-0  
info@reflex.de

[www.reflex-winkelmann.com/en](https://www.reflex-winkelmann.com/en)