

6.1 Installation conditions

6.1.1 Incoming inspection

Prior to shipping, this device was carefully inspected and packed. Damages during transport cannot be excluded.

Proceed as follows:

1. Upon receipt of the goods, check the shipment for
 - completeness and
 - possible transport damage.
2. Document any damage.
3. Contact the forwarding agent to register your complaint.

6.2 Preparatory work

Condition of the delivered device:

- Check all screw connections of the device for tight seating. Tighten the screws as necessary.

Preparing the device installation:

- No access by unauthorised personnel.
- Frost-free, well-ventilated room.
 - Room temperature 0 °C to 45 °C (32 °F to 113 °F).
- Level, stable flooring.
 - Ensure sufficient bearing strength of the flooring before filling the tanks.
 - Ensure that the control unit and the tanks are installed on the same level.
- Filling and dewatering option.
 - Provide a DN 15 filling connection according to DIN 1988 - 100 and En 1717.
 - Provide an optional cold water inlet.
 - Prepare a drain for the drain water.
- Electric connection, see chapter 5 "Technical data" on page 15 .
- Use only approved transport and lifting equipment.
 - The load fastening points at the tanks must be used only as installation resources.

6.3.5 Fitting the level sensor

ATTENTION

Damage to the pressure load cell due to unprofessional installation

Incorrect installation may result in damage to the "LIS" level sensor, malfunctioning and incorrect measurements from the pressure load cell.

- Comply with the instructions regarding the installation of the pressure load cell.

The "LIS" level sensor uses a pressure load cell. This pressure pick-up is to be installed after the primary tank has been placed at its final position, see chapter 6.3.2 "Tank installation" on page 20 . Comply with the following instructions:

- Remove the transport securing device (squared timber) at the vessel base of the primary tank.
- Replace this transport securing device with the pressure load cell.
 - In the case of a tank volume of 1000 l (Ø 1000 mm) or more, use the supplied screws to attach the pressure load cell at the vessel base of the primary tank.
- Avoid shock-type loading of the pressure load cell by, for example, subsequent alignment of the vessel.
- Use flexible hoses to connect the primary tank and the first secondary tank.
 - Use only the supplied connection sets, see chapter 6.3.2 "Tank installation" on page 20 .
- Perform a null balancing of the filling level when the primary tank is aligned and fully emptied, see chapter 9.3 "Configuring settings in the controller" on page 46 .

Standard values for level measurements:

Primary vessel	Measuring range
200 l	0 – 4 bar
300 – 500 l	0 – 10 bar
600 – 1000 l	0 – 25 bar
1500 – 2000 l	0 – 60 bar
3000 – 5000 l	0 – 100 bar

7.2 Determining the P₀ minimum operating pressure for the controller

The "P₀" minimum operating pressure is determined by the location of the pressure maintaining device. The controller calculates the switching points for the "PV" solenoid valve and the "CO" compressor from the "P₀" minimum operating pressure.

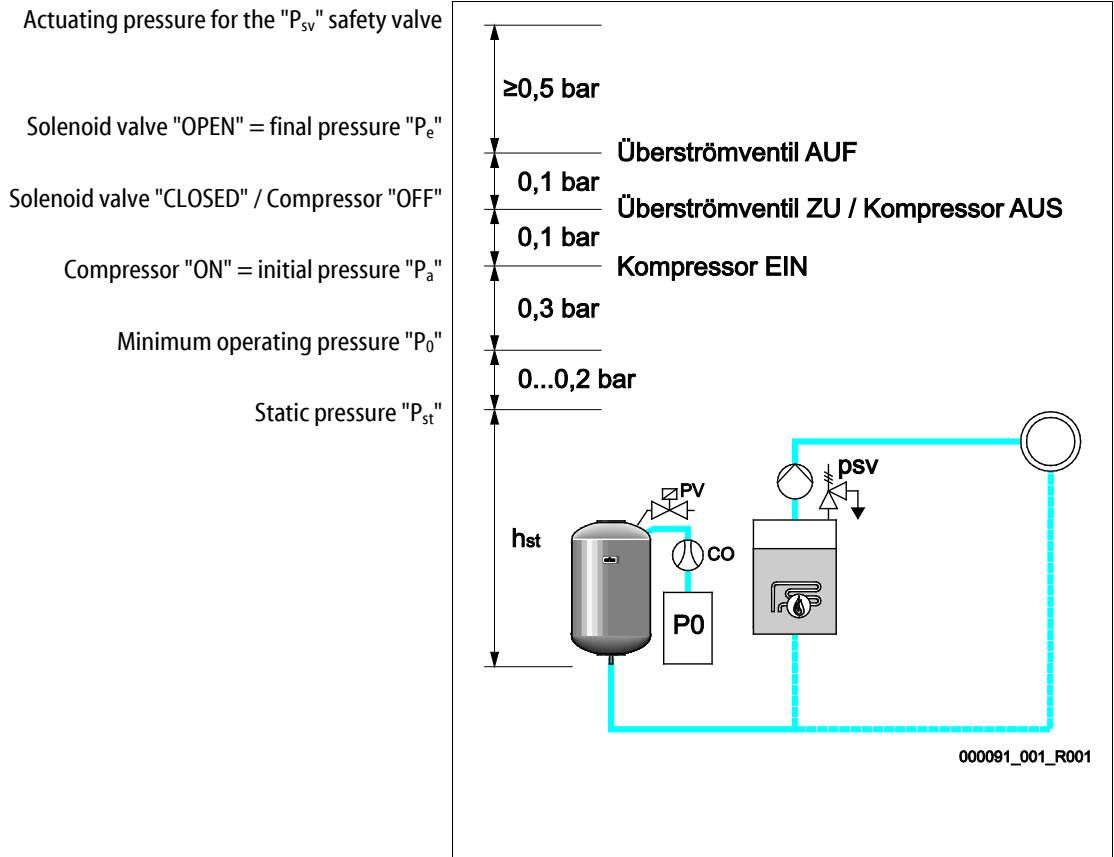

The "P₀" minimum operating pressure is calculated as follows:

$P_0 = P_{st} + P_D + 0.2 \text{ bar}^*$	Enter the calculated value in the start routine of the controller, see chapter 7.3 "Modifying the controller's start routine" on page 36 .
$P_{st} = h_{st}/10$	h_{st} in metres
$P_D = 0.0 \text{ bar}$	for safety temperatures $\leq 100 \text{ }^\circ\text{C}$
$P_D = 0.5 \text{ bar}$	for safety temperatures $= 110 \text{ }^\circ\text{C}$

*Addition of 0.2 bar recommended, no addition in extreme cases

Calculation example for "P₀" minimum operating pressure:

Heating system: Static height 18 m, run-on temperature 70 °C, safety temperature 100 °C.

Calculation example:

$$P_0 = P_{st} + P_D + 0.2 \text{ bar}^*$$

$$P_{st} = h_{st}/10$$

$$P_{st} = 18 \text{ m}/10$$

$$P_{st} = 1.8 \text{ bar}$$

$$P_D = 0.0 \text{ bar at a safety temperature of } 100 \text{ }^\circ\text{C}$$

$$P_0 = 1.8 \text{ bar} + 0 \text{ bar} + 0.2 \text{ bar}$$

$$P_0 = 2.0 \text{ bar}$$



Notice!

Avoid dropping below the "P₀" minimum operating pressure. Vacuum, vaporisation and cavitation are thus excluded.

7.3 Modifying the controller's start routine



Note!

During commissioning, you must once execute the start routine.

- For information about controller operation, see chapter 9.1 "Operator panel" on page 44 .

The start routine is used to adjust the required parameters for the device commissioning. It commences with the first activation of the controller and can be run only once. The settings can be changed or checked in the Customer menu after the start routine has terminated see chapter 9.3.1.1 "Customer menu – overview" on page 46 .

A three-digit PM code is assigned to the setting options.

Step	PM code	Description
1		Start of the start routine
2	001	Select the language
3		Remember: Prior to installation and commissioning, read the operating manual!
4	005	Set the "P ₀ " minimum operating pressure, see chapter 7.2 "Determining the P ₀ minimum operating pressure for the controller" on page 35 .
5	002	Set the time
6	003	Set the date
7	121	Select the primary tank nominal volume
8		Null balancing: The primary tank must be completely empty. The system checks whether the signal from the level sensor matches the selected primary tank
		End of the start routine. The stop mode is active.



Note!

Provide the power supply (230 V) for the controller by pressing the main switch at the control unit.

The system automatically displays the first page of the start routine when you switch on the device for the first time.

1. Press "OK".
 - The start routine moves to the next page.

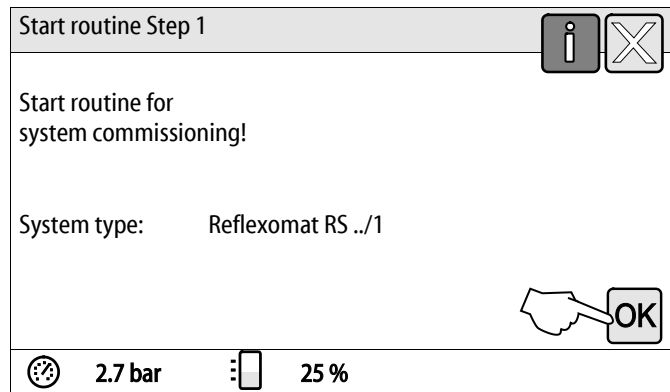

9 Controller

9.1 Operator panel

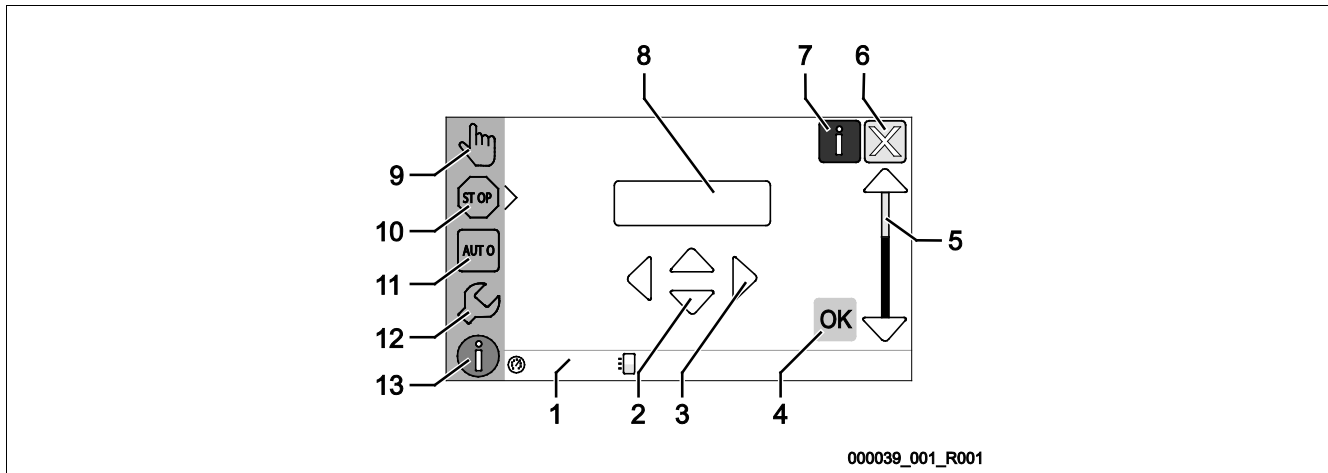

1	Message line
2	"▼"/"▲" buttons • Set digits.
3	"◀"/"▶" buttons • Select digits.
4	"OK" button • Confirm/acknowledge input. • Browse in the menu.
5	"Up" and "Down" scroll bar • "Scroll" in the menu.
6	"Scroll back" button • Cancel. • Move backward up to the main menu.
7	"Display help texts" button • Opens help texts.

8	Display value
9	"Manual mode" button • For function tests.
10	"Stop mode" button • For commissioning.
11	"Automatic mode" button • For continuous operation.
12	"Set-up menu" button • For setting parameters. • Fault memory. • Parameter memory. • Display settings. • Primary tank information. • Software version information.
13	"Info menu" button • Displays general information.

9.3 Configuring settings in the controller

You can configure the controller settings regardless of the currently selected and active operating mode.

9.3.1.1 Customer menu – overview

Use the Customer menu to correct or determine system-specific values. In the course of commissioning, the factory settings must be adjusted for the system-specific conditions.



Note!

For a description of the operation, see chapter 9.1 "Operator panel" on page 44 .

A three-digit PM code is assigned to the setting options.

PM code	Description
001	Select the language
002	Set the time
003	Set the date
	Execute null balancing <ul style="list-style-type: none"> – The primary tank must be empty! – The system checks whether the signal from the level sensor matches the selected primary tank.
005	Set the P ₀ minimum operating pressure, see chapter 7.2 "Determining the P ₀ minimum operating pressure for the controller" on page 35 .
	Make-up >
021	• Make-up ON at ... %
022	• Make-up OFF at ... %
023	• Maximum make-up time ... min
024	• Maximum make-up cycles ... /2 h
027	• With contact water meter "Yes/No" <ul style="list-style-type: none"> – If "Yes", continue with 028
028	• Reset make-up quantity "Yes/No"
029	• Maximum make-up quantity ... l
030	• With softening "Yes/No" <ul style="list-style-type: none"> – If "Yes", continue with 031
031	• Block make-up "Yes/No" (if water capacity is exhausted)
033	• Hardness reduction ... °dH = GH _{actual} – GH _{target}
032	• Soft water capacity <ul style="list-style-type: none"> • Fillsoft I: Soft water capacity = 6000 l / hardness reduction • Fillsoft II: Soft water capacity = 12000 l / hardness reduction
034	• replacement interval... months (for softening cartridges according to manufacturer).
007	Maintenance interval... months
008	Floating contact <ul style="list-style-type: none"> • Message selection > <ul style="list-style-type: none"> • Message selection: only messages marked with "√" are output. • All messages: All messages are output.
	Fault memory > History of all messages
	Parameter memory > History of parameter input
	Display settings > Brightness, screen saver
009	• Brightness ... %
010	• Screen saver brightness ... %
011	• Screen saver delay ... min
	Information > <ul style="list-style-type: none"> • Tank: Tank information • Software version

10.3 Cleaning

10.3.1 Cleaning the tanks

CAUTION

Risk of injury due to pressurised liquid

Injuries can occur during maintenance work if the connections have been installed incorrectly because condensate under pressure can suddenly escape.

- Ensure proper connections for the draining of condensate.
- Wear suitable personal protective equipment (safety gloves and safety goggles, for example).

Regularly clean the primary tank and the secondary tanks from condensate. The cleaning intervals depend on the local operational conditions.

Tanks with replaceable diaphragm

1. Close the cap valves upstream of the tanks.
2. Record the displayed level value at the controller and empty the tank of water and compressed air.
3. Switch off the main switch and withdraw the mains plug.
4. Open the drain taps at the tanks and drain the condensate.
 - If more than 5 litres of water or condensate are discharged, you must check the tank.
 - Check the diaphragm for rupture.
 - Check the tank interior walls for corrosion damage.

 **CAUTION** – Risk of injury caused by escaping pressurised liquid. Injuries can occur during maintenance work if the connections have been installed incorrectly because condensate under pressure can suddenly escape.

5. Close the tanks' drain taps.
6. Connect the mains plug and switch on the main switch.
7. Open the cap valves of the tanks and secure against unauthorised "closing".
8. Fill water and compressed air into the tanks until the recorded level value is reached.

Maintenance is completed.



Note!

Check the installation location of the tanks for sufficient ventilation if the tank interior wall are damaged by corrosion, see chapter 6.2 "Preparatory work" on page 18.

10.3.2 Cleaning the dirt trap

Regularly clean the "ST" dirt trap. The cleaning intervals depend on the local operational conditions.

1. Switch to Stop mode.
 - Press "Stop" on the controller's operator panel.
2. Close the ball valves upstream and downstream of the "ST" (1) dirt trap.
3. Slowly unscrew the dirt trap insert (2) from the dirt trap in order for the residual pressure to escape from the pipeline segment.
4. Pull the mesh from the dirt trap insert and rinse it with clear water. Use a soft brush for cleaning.
5. Re-insert the mesh into the dirt trap insert, check the gasket for damage, and screw the dirt trap insert back into the housing of the "ST" (1) dirt trap.
6. Re-open the ball valves upstream and downstream of the "ST" (1) dirt trap.
7. Switch to Automatic mode.
 - Press "Auto" on the controller's operator panel.

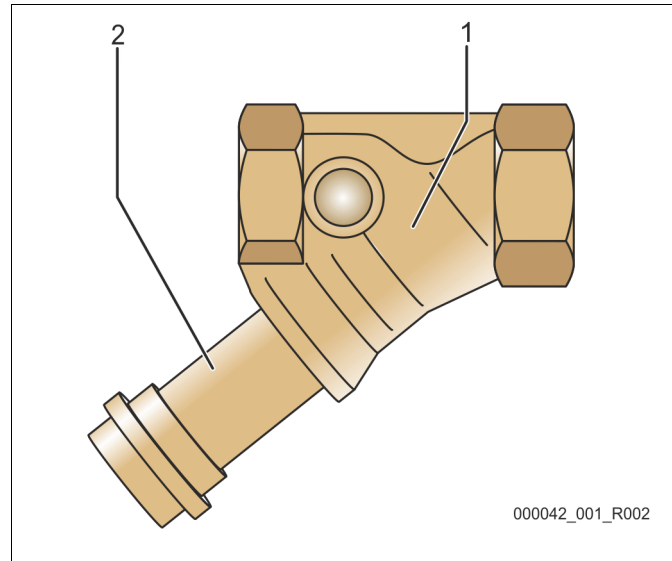

1	"ST" dirt trap	2	Dirt trap insert
---	----------------	---	------------------

**Note!**

Clean all other installed dirt traps (in the Reflex Fillset, for example).

10.5 Inspection

10.5.1 Pressure-bearing components

Comply with all applicable national regulations for the operation of pressure equipment. De-pressurise all pressurised components prior to inspection (see disassembly information).

10.5.2 Inspection prior to commissioning

In Germany, follow the Industrial Safety Regulation [Betriebssicherheitsverordnung] Section 15 and Section 15 (3) in particular.

10.5.3 Inspection intervals

Recommended maximum inspection intervals for operation in Germany pursuant to Section 16 of the Industrial Safety Regulation [Betriebssicherheitsverordnung] and the vessel classification of the device in diagram 2 of the Directive 2014/68/EC, applicable in strict compliance with the Reflex Installation, Operation and Maintenance Manual.

External inspection:

No requirement according to Annex 2, Section 4, 5.8.

Internal inspection:

Maximum interval according to Annex 2, Section 4, 5 and 6; if necessary, suitable replacement actions are to be taken (such as wall thickness measurement and comparison with the design specification which may be requested from the manufacturer).

Tightness test:

Maximum interval according to Annex 2, Section 4, 5 and 6.

Furthermore, compliance with Section 16 of the Industrial Safety Regulation and Section 16 (1) in particular, in conjunction with Annex 2, Section 4, 6.6 and Annex 2, Section 4, 5.8, must be ensured.

The actual intervals must be determined by the user on the basis of a safety-technical assessment taking into account the real operational conditions, the experience with the operation and the charging material, and the national regulations for the operation of pressure equipment.



Thinking solutions.

Reflex Winkelmann GmbH
Gersteinstraße 19
59227 Ahlen, Germany

Telephone: +49 (0)2382 7069-0
Fax: +49 (0)2382 7069-588
www.reflex.de